

CATALOGUE

Trains and Buses

Antennas and
Antenna Line Products



MOBILE
COMMUNICATION

KATHREIN

Who we are and what we stand for

Kathrein is a leading international specialist for reliable, high-quality communication technologies.

We are an innovation and technology leader in today's connected world. Our ability to provide solutions and systems enables people all over the world to communicate, access information and use media, whether at home, at the office or on the road. We cover a broad spectrum: from mobile communications, signal enhancement and

data transmission in buildings, to fibre optic and cable networks and satellite reception technology, to radio and TV transmission and transmission and reception systems in vehicles.

As a hidden champion and family-owned enterprise, we have been working on the technologies of tomorrow since 1919. We take pride in our dedicated employees and our passion for customers and quality.

Our Solutions

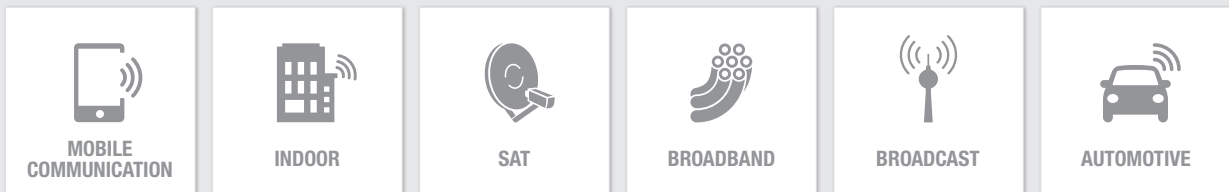

Find out more about us at www.kathrein.com

Catalogue Issue 02/2015

All data published in previous catalogue issues hereby becomes invalid.

We reserve the right to make alterations in accordance with the requirements of our customers, therefore for binding data please check valid data sheets on our homepage: www.kathrein.com

Please note:

The details given in our data sheets have to be followed carefully when installing the antennas and accessories. The installation team must be properly qualified and also be familiar with the relevant national safety regulations.



Our quality assurance system and our environmental management system apply to the entire company and are certified by TÜV according to EN ISO 9001 and EN ISO 14001.



Our products are compliant to the EU Directive RoHS as well as to other environmentally relevant regulations (e.g. REACH).

Summary

Antennas for trains and buses

68 ... 3800 MHz

Frequency band	Type No.	Operating frequency range	Type approved by "Deutsche Bahn AG"	Remarks	Page
FM radio	727313	87.5 – 108 MHz	Yes	Only for receiving	7
2 m-band	K502221 . K502222 .	146 – 156 MHz 156 – 174 MHz		Low profile	8
	733707	146 – 174 MHz	Yes		9
70cm-band	87010008	380 – 430 MHz	Yes		10
	K70232. .	406 ... 470 MHz		Low profile	12
	K702021	410 – 470 MHz	Yes		13
	725892 K702121	410 – 430 MHz 450 – 470 MHz	Yes	Gain 2 dB	14
70cm-band 800/900 MHz	741557	380 – 400 MHz 870 – 960 MHz	Yes	Two-band antenna	15
	87010009	430 – 470 MHz 870 – 960 MHz	Yes	Two-band antenna	16
	K702061	450 – 470 MHz 790 – 960 MHz	Yes	Two-band antenna	18
900 MHz	741009	870 – 960 MHz	Yes	Special radome	19
	K7021631	876 – 960 MHz	Yes	Gain 3.5 dB	20
800/900/1800 MHz / UMTS / LTE / WLAN / WIMAX	87010007	790 – 2700 MHz	Yes	Low profile	21
1800/1900 MHz / UMTS / LTE / WLAN / WIMAX	87010010	1710 – 3800 MHz	Yes	Low profile	23

Antennas with integrated GPS-Module

70cm-band / GPS	87010005	380 – 430 MHz 1575.42 ± 1 MHz	Yes		11
70cm-band / 900 MHz / GPS	87010006	430 – 470 MHz 870 – 960 MHz 1575.42 ± 1 MHz	Yes		17
800/900/1800 MHz / UMTS / LTE / WLAN / WIMAX / GPS	87010003	790 – 2700 MHz 1575.42 ± 1 MHz	Yes	Low profile	22
1800/1900 MHz / UMTS / LTE / WLAN / WIMAX / GPS	87010011	1710 – 3800 MHz 1575.42 ± 1 MHz	Yes	Low profile	24
GPS	86010142	1575.42 ± 1 MHz		Low noise amplifier	25

Installation Guidelines see from page 26 onwards

Additional antenney types available on request. Please contact: mobilcom@kathrein.de

Article summary

KATHREIN

The articles are listed by type number
in numerical order

Type No.	Page	Type No.	Page
719792	5	78211280, 1, 2, 3, 4, 5	5
721138	5	78211320, 321, 322, 323	5
725892	14	78211400, 1, 2, 3, 4, 5, 6, 7, 8, 9	5
727313	7	790244	5
728954	5, 15, 18	86010142	25
733707	9	87010003	22
741009	19	87010005	11
741557	15	87010006	17
78210264	5	87010007	21
78210278, 279	5	87010008	10
78210305, 306	5	87010009	16
78210341	5	87010010	23
78210369	5	87010011	24
78210379	5	K5022211	8
78210460	5	K5022212	8
78210469	5	K5022221	8
78210620, 1, 2, 3, 4, 5, 6	5	K5022222	8
78210630, 1, 2, 3, 4, 5	5, 6	K64504	5
78210640, 1, 2, 3, 4, 5, 9	5	K702021	13
78210660, 1, 2, 3, 4, 5, 9	5	K702061	18
78210680, 681, 682, 683	5	K702121	14
78210800	5	K7021631	20
78210808, 809, 810	5	K702321	12
78210900, 901	5	K7023210	12
78210970, 1, 2, 3, 4, 5, 9	5	K7023211	12
78211091, 2, 3, 4, 5, 9	5	K702323	12
78211130, 1, 2, 3, 4, 5	5	K7023230	12
78211180, 1, 2, 3, 4, 5, 9	5	K7023231	12
78211190, 191, 192, 193	5		

Frequency Combinations

Type No.	Frequency / MHz														
	PMR 200	400	LTE800 600	GSM/UMTS900 800	1000	1200	1400	1600	GSM1800 1800	UMTS2100 2000	2200	WLAN 2400	LTE2600/WiMax 2600	2800	3000
Dual-band Combiners															
K64504			68 - 87.5 / 146 - 174												
719792			68 - 108 / 146 - 174												
721138			68 - 174	380 - 470											
790244			68 - 174	400 - 470											
78210369, 78210379			380 - 400	410 - 430											
728954			68 - 470				870 - 970								
78210460			50 - 470							790 - 2500					
78211280, ..1 ..2 ..3 ..4 ..5			698 - 806	824 - 960											
78210341			824 - 880	890 - 960											
78210970, ..1 ..2 ..3 ..4 ..5 ..9			790 - 862	880 - 960											
78211320, ..321 ..322 ..323				698 - 894						1710 - 2400					
78210660, ..1 ..2 ..3 ..4 ..5 ..9			470 - 960							1710 - 2700					
78210680, ..681 ..682 ..683			380 - 960							1710 - 2700					
78210900, 78210901			380 - 960							1710 - 2690					
78210278, ..279 ..305 ..306							790 - 1880				1920 - 2170				
78210620, ..1 ..2 ..3 ..4 ..5 ..6								1710 - 1880				1920 - 2170			
78210264										50 - 2200				2400 - 2500	
78210800, 78211091, ..2 ..3 ..4 ..5 ..9										1710 - 2180				2400 - 2700	
78211180, ..1 ..2 ..3 ..4 ..5 ..9										380 - 2180				2400 - 2700	
78210469, ..808 ..809 ..810								1710-1755	1850 - 1990		2110-2155				
Triple-Band Combiners															
78210630, ..1 ..2 ..3 ..4 ..5			380 - 960					1710 - 1880			1920 - 2170				
78211130, ..1 ..2 ..3 ..4 ..5			790 - 960							1710 - 2180				2490 - 2690	
78211190, ..191 ..192 ..193			791 - 862	880 - 960						1710 - 2690					
78211400, ..1 ..2 ..3 ..4 ..5 ..6 ..7 ..8 ..9								1710 - 1880		1920 - 2170		2300 - 2700			
Quad-Band Combiners															
78210640, ..1 ..2 ..3 ..4 ..5 ..9			380 - 960					1710 - 1880		1920 - 2200				2500 - 2690	

For multi-band antennas, several combiners for combining the bands are available. All devices undergo vibration- und shock tests according to ETS-300019-1-4.

Separate catalogues and our homepage www.kathrein.com provide information for the combiners. Of course any question may also be directly put to mobilcom@kathrein.de.

For multi-band antennas, several combiners for combining the bands are available. All devices undergo vibration- und shock tests according to ETS-300019-1-4.

Separate catalogues and our homepage <www.kathrein.com> provide information for the combiners. Of course any question may also be directly put to mobilcom@kathrein.de.



Triple-band Combiner GSM-R/GSM 900 – GSM 1800 – UMTS

Example:

Triple-band Combiners

Type No.	78210630, Single Unit 78210631, Double Unit	78210632, Single Unit 78210633, Double Unit	78210634, Single Unit 78210635, Double Unit
Pass band Band 1 (TETRA ... GSM 900) Band 2 (GSM 1800) Band 3 (UMTS)		380 – 960 MHz 1710 – 1880 MHz 1920 – 2170 MHz	
Insertion loss Port 1 ↔ Port 4 Port 2 ↔ Port 4 Port 3 ↔ Port 4		< 0.2 dB (380 – 960 MHz) < 0.3 dB (1710 – 1880 MHz) < 0.3 dB (1920 – 2170 MHz)	
Isolation Port 1 ↔ Port 2 Port 1 ↔ Port 3 Port 2 ↔ Port 3		> 45 dB (380 – 600 MHz) / > 50 dB (600 – 960 / 1710 – 1880 MHz) > 45 dB (380 – 600 MHz) / > 50 dB (600 – 960 / 1920 – 2170 MHz) > 50 dB (1710 – 1880 / 1920 – 2170 MHz)	
VSWR		< 1.25 (380 – 960 / 1710 – 1880 / 1920 – 2170 MHz)	
Impedance		50 Ω	
Input power Band 1 / Band 2 / Band 3		< 700 W / < 300 W / < 300 W	
Intermodulation products		< -160 dBc (3rd order; with 2 x 20 W)	
Temperature range		-40 ... +60 °C	
Connectors		7-16 female (long neck)	

Train Antenna

87.5 – 108 MHz

727313

KATHREIN

- FM-broadcast receiving antenna for rail vehicles in fiberglass radome.
- Only for receiving.

Type No.	727313
Input	N female
Frequency range	87.5 – 108 MHz
Impedance	50 Ω
Polarization	Vertical
Radome weight	365 g
Total weight	900 g
Packing size (outside)	151 x 90 x 415 mm

Material: Flange: Aluminum.
Radiator: Copper.
Radome: Fiberglass; Colour: Light grey.
All screws and nuts: Stainless steel.
Sealing: Neoprene and EPDM. **Note:** Don't use detergents that might harm the sealing.

Mounting: On a conductive surface with a minimum size of 100 x 200 cm by means of existing M10 studs.

Grounding and high voltage protection: This antenna approved by the "Deutsche Bahn AG" is DC grounded to protect against lightning and high-tension lines.

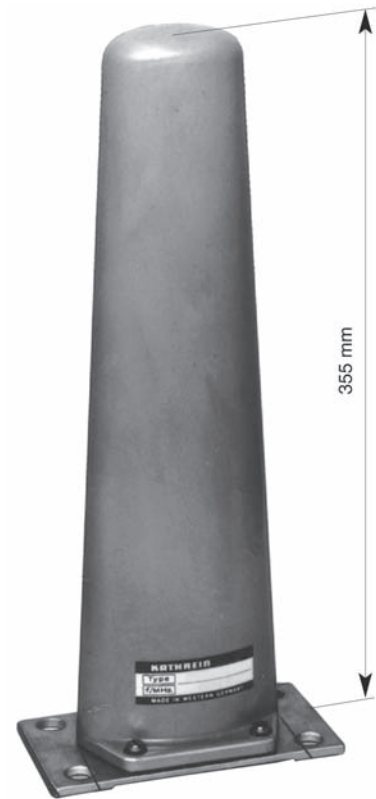

Mounting flange:

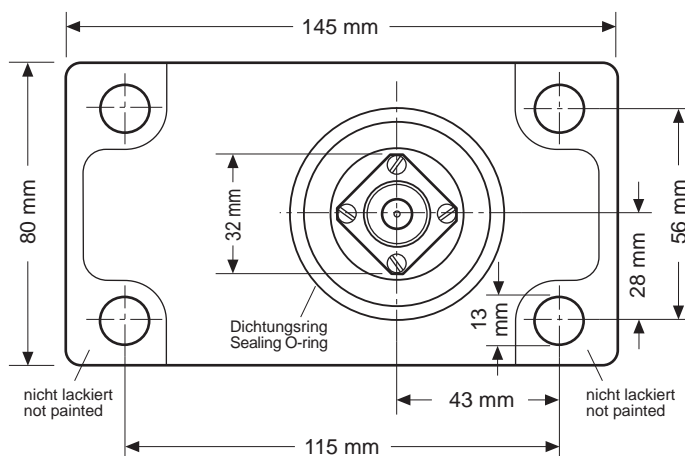

Mounting hole for the connector: 33 (max. 35) mm diameter.

Note: Keep mounting surface clear of paint for electrical contact.

Tram and Bus Antenna

146 – 174 MHz

K50222..

KATHREIN

- Broadband antenna in fiberglass radome.

Type No.	K5022211	K5022212
Input	N female	UHF female
Frequency range	143 – 162 MHz but preferred range 146 – 156 MHz	
VSWR	< 1.4	
Gain	0 dB (ref. to the quarter-wave antenna)	
Impedance	50 Ω	
Polarization	Vertical	
Max. power	100 W (at 50° C ambient temperature)	
Radome weight	470 g	
Total weight	1200 g	
Packing size	260 x 260 x 130 mm	

Type No.	K5022221	K5022222
Input	N female	UHF female
Frequency range	152 – 178 MHz but preferred range 156 – 174 MHz	
VSWR	< 1.4	
Gain	0 dB (ref. to the quarter-wave antenna)	
Impedance	50 Ω	
Polarization	Vertical	
Max. power	100 W (at 50° C ambient temperature)	
Radome weight	470 g	
Total weight	1200 g	
Packing size	260 x 260 x 130 mm	

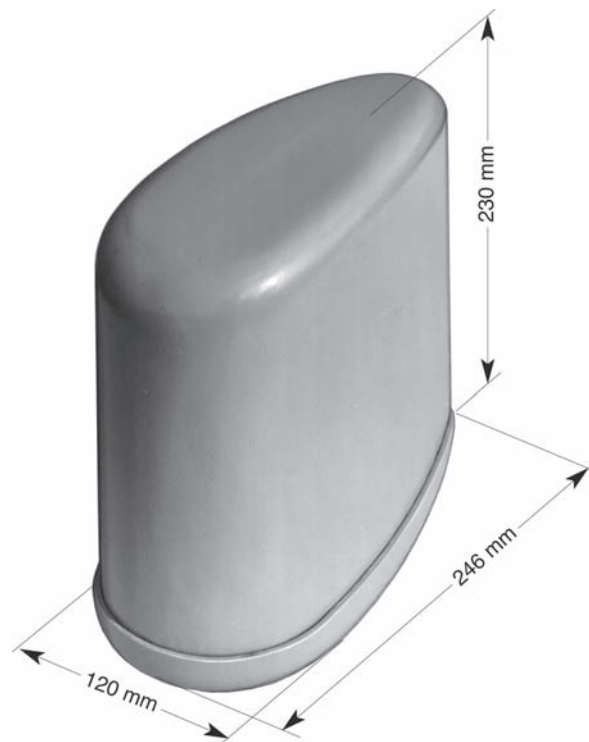

- Material:** Radiator and Base: Aluminum.
Radome: Fiberglass, colour: Grey.
Studs and all screws and nuts: Stainless steel.
Sealing: Neoprene and polyurethane. **Note:** Don't use detergents that might harm the sealing.
- Mounting:** On a conductive surface 1.0 x 2.0 m min. with 3 studs M10 and counterflange.
Note: No superstructures in this area.
- Grounding and high voltage protection:** DC grounded to protect against lightning and high-tension lines.
- Scope of supply:** Antenna with 3 studs, each with 2 nuts, 1 rubber gasket and 1 counterflange.

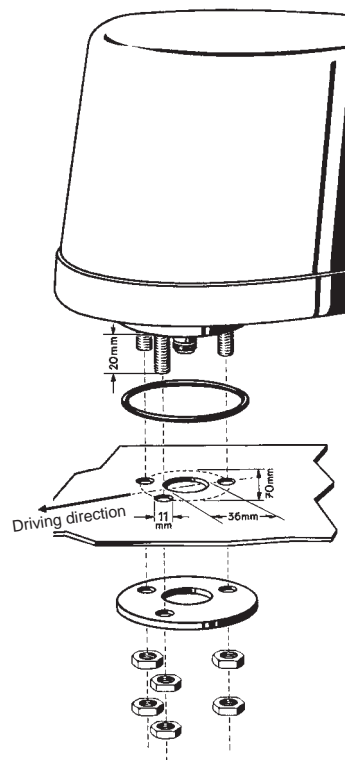

Train Antenna 146 – 174 MHz 733707

KATHREIN

- Aluminum antenna in fiberglass radome.

Type No.	733707
Input	N female
Frequency range	146 – 174 MHz
VSWR	< 2.0
Gain	0 dB (ref. to the quarter-wave antenna)
Impedance	50 Ω
Polarization	Vertical
Max. power	100 W (at 50 °C ambient temperature)
Radome weight	365 g
Total weight	800 g
Packing size (outside)	151 x 90 x 415 mm

Material: Radiator and flange: Aluminum.
Radome: Fiberglass, colour: Light grey.
All screws and nuts: Stainless steel.
Sealing: Neoprene and EPDM. **Note:** Don't use detergents that might harm the sealing.

Mounting: On a conductive surface 200 x 100 cm min. with 4 studs M10.

Grounding and high voltage protection: This antenna approved by the "Deutsche Bahn AG" is DC grounded to protect against lightning and high-tension lines.

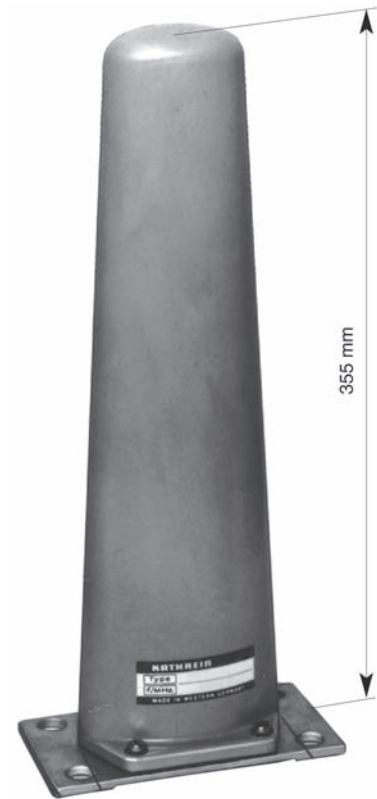

Mounting flange:

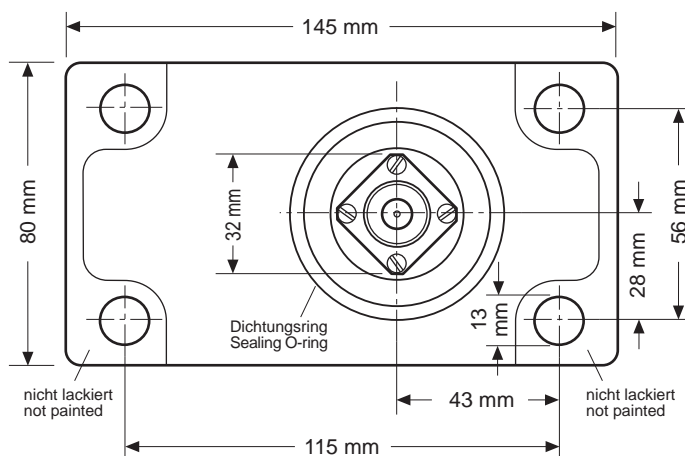

Mounting hole for the connector: 33 (max. 35) mm diameter.

Note: Keep mounting surface clear of paint for electrical contact.

Train Antenna

380 – 430 MHz

87010008

KATHREIN

- Low profile antenna in fiberglass radome.
- The antenna fulfils the requirements according to EN 50155.

Type No.	87010008
Antenna	
Input	N female
Frequency range	380 – 430 MHz
VSWR	< 1.7
Gain	0 dB (ref. to the quarter-wave antenna)
Impedance	50 Ω
Polarization	Vertical
Max. power	100 W (at 50° C ambient temperature)
Inner conductor	DC grounded
Radome weight	186 g
Total weight	Approx. 500 g
Packing size, L x W x H	150 x 90 x 190 mm
Height	150 mm

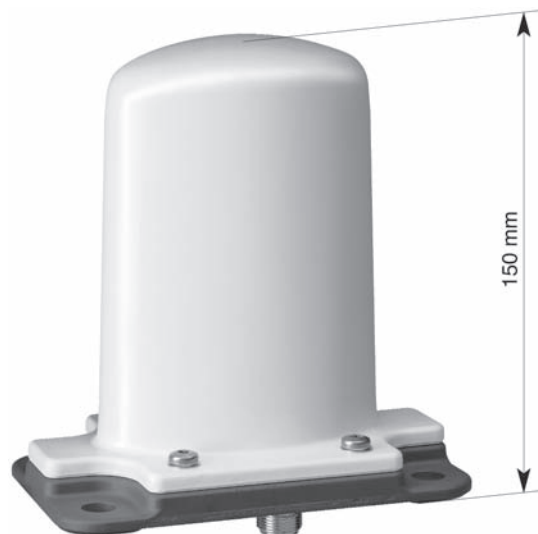

Material: Radiator: Copper and brass.
Flange: Aluminum. Radome: Fiberglass.
All screws and nuts: Stainless steel.
Colour: Grey.
Sealing: Neoprene and silicon. **Note:** Don't use detergents that might harm the sealing.

Mounting: On a conductive surface with a minimum size of 1000 x 1000 mm using 4 M10 bolts.

Grounding and high voltage protection: This antenna, tested by an independent institute and approved by the "Deutsche Bahn AG", is DC grounded to protect against lightning and high-tension lines.

Mounting flange:

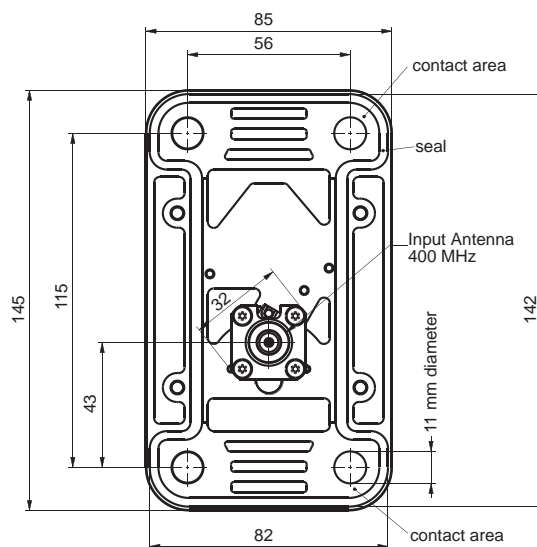

Mounting hole for the connector: 33 (max. 35) mm diameter.

Note: Keep mounting surface clear of paint for electrical contact.

Evenness of opposite surface 0.2 mm.

Use a cap nut or hex-head screw plus the enclosed sealing washer.

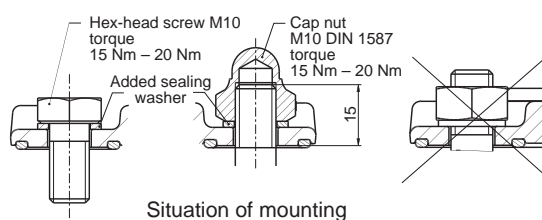

Train Antenna

380 – 430 MHz and GPS 1575 MHz

87010005

- Two-band antenna: 380 – 430 MHz and GPS.
- The antenna can be operated in both frequency ranges simultaneously.
- Low profile antenna in fiberglass radome.
- The antenna fulfils the requirements according to EN 50155.

Type No.	87010005
Antenna 380 – 430 MHz	
Input	N female
Frequency range	380 – 430 MHz
VSWR	< 1.7
Gain	0 dB (ref. to the quarter-wave antenna)
Impedance	50 Ω
Polarization	Vertical
Max. power	100 W (at 50° C ambient temperature)
Inner conductor	DC grounded
Antenna GPS	
Input	Cable RG 316/U of 225 mm length with TNC male connector
Frequency range	1575.42 ±1 MHz
VSWR	< 1.5
Polarization	Right hand circular
Gain (90° elevation)	2 dB (ref. to the circularly polarized isotropic antenna)
Impedance	50 Ω
Inner conductor	DC grounded
Radome weight	186 g
Total weight	Approx. 500 g
Packing size	150 x 90 x 190 mm
Height	150 mm

Material: Radiator: Copper and brass.
Flange: Aluminum. Radome: Fiberglass.
All screws and nuts: Stainless steel.
Colour: Grey.
Sealing: Neoprene and silicon. **Note:** Don't use detergents that might harm the sealing.

Mounting: On a conductive surface with a minimum size of 1000 x 1000 mm using 4 M10 bolts.

Grounding and high voltage protection: This antenna, tested by an independent institute and approved by the "Deutsche Bahn AG", is DC grounded to protect against lightning and high-tension lines.

Accessories: Low noise amplifier GPS 86010142 (please order separately).

Warning: If the antenna is operated without the pre-amplifier type no. 86010142, please note the following points.

- Due to the fact that the inner conductor of the antenna GPS is DC grounded, the input of the GPS receiver is loaded with a DC short circuit. If the GPS receiver provides a remote DC power supply, this could damage the GPS receiver.
- At the input of the antenna GPS a level of –25 dB below the signal applied at the input of the antenna 380 – 430 MHz appears. Depending on the level of the signal applied at the input of the antenna 380 – 430 MHz, the GPS receiver may be overloaded or damaged.



Mounting flange:

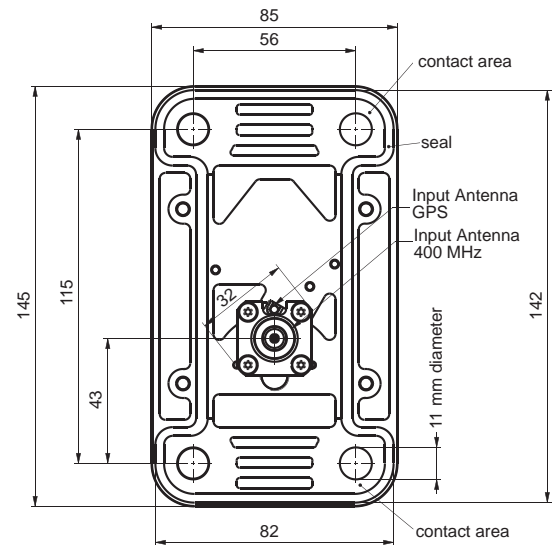

Mounting hole for the connector: 33 (max. 35) mm diameter.

Note: Keep mounting surface clear of paint for electrical contact.

Evenness of opposite surface 0.2 mm.

Use a cap nut or hex-head screw plus the enclosed sealing washer.

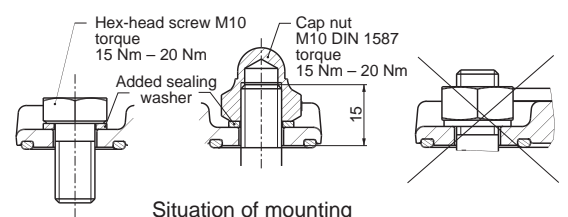

Situation of mounting

Tram and Bus Antenna

406 ... 470 MHz

K702321., K702323.

KATHREIN

Frequency range 406 – 428 MHz

Type No.	K7023210	K702321	K7023211
Input	M 11 x 1 female (the connector for cable RG 58 C/U is supplied).	M 11 x 1 female (the connector for cable RG 213/U is supplied).	N female
Drill hole dimension	12 mm	12 mm	17 mm
Frequency range	406 – 428 MHz		
VSWR	406 – 410 MHz: < 1.9 410 – 425 MHz: < 1.7 425 – 428 MHz: < 1.9		
Gain	0 dB (ref. to the quarter-wave antenna)		
Impedance	50 Ω		
Polarization	Vertical		
Max. power	50 W (at 50 °C ambient temperature)		
Weight	0.40 kg		
Packing size (outside)	117 x 117 x 114 mm		
Height	70 mm		
Mounting	On a conductive surface 70 x 70 cm min.		

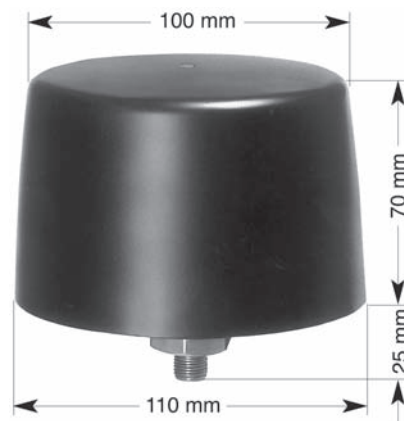

Frequency range 440 – 470 MHz

Type No.	K7023230	K702323	K7023231
Input	M 11 x 1 female (the connector for cable RG 58 C/U is supplied).	M 11 x 1 female (the connector for cable RG 213/U is supplied).	N female
Drill hole dimension	12 mm	12 mm	17 mm
Frequency range	440 – 470 MHz		
VSWR	440 – 450 MHz: < 1.7 450 – 465 MHz: < 1.5 465 – 470 MHz: < 1.7		
Gain	0 dB (ref. to the quarter-wave antenna)		
Impedance	50 Ω		
Polarization	Vertical		
Max. power	50 W (at 50 °C ambient temperature)		
Weight	0.40 kg		
Packing size (outside)	117 x 117 x 114 mm		
Height	70 mm		
Mounting	On a conductive surface 50 x 50 cm min.		

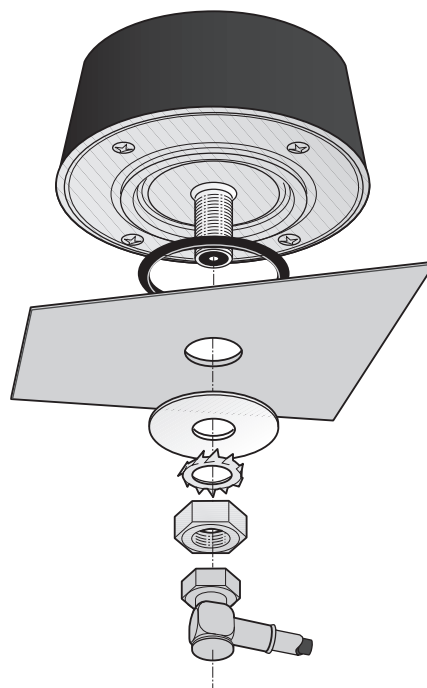

Material: Radiator and base: Aluminum.
Radome: High impact plastic.
All screws and nuts: Stainless steel.

Mounting: The drilling diameter is 12 mm except the N connector versions: 17 mm.
A special zinc washer ensures a good contact at the edges of the hole.

Special features: All metall parts of this antenna are DC grounded.
Extreme robust and car-wash proof vehicular antenna.

Train Antenna 410 – 470 MHz K702021

KATHREIN

- Low profile broadband antenna in fiberglass radome.

Type No.	K702021
Input	N female
Frequency range	410 – 470 MHz
VSWR	< 1.5
Gain	0 dB (ref. to the quarter-wave antenna)
Impedance	50 Ω
Polarization	Vertical
Max. power	170 W (at 50° C ambient temperature)
Radome weight	159 g
Total weight	500 g
Packing size (outside)	151 x 87 x 210 mm

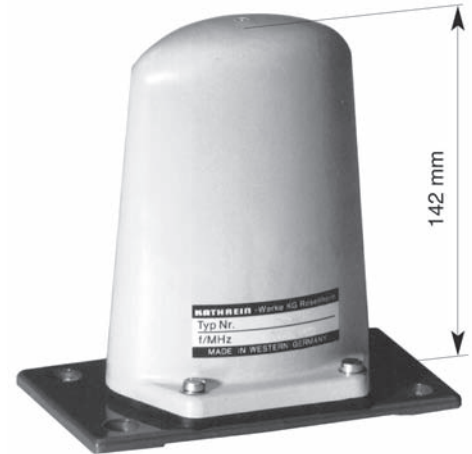

Material: Radiator and Flange: Aluminum.
Radome: Fiberglass, colour: Light grey.
All screws and nuts: Stainless steel.
Sealing: Neoprene and rubber. **Note:** Don't use detergents that might harm the sealing.

Mounting: On a conductive surface with a minimum size of 50 x 50 cm by means of existing M10 studs.

Grounding and high voltage protection: This antenna approved by the "Deutsche Bahn AG" is DC grounded to protect against lightning and high-tension lines.

Mounting flange:

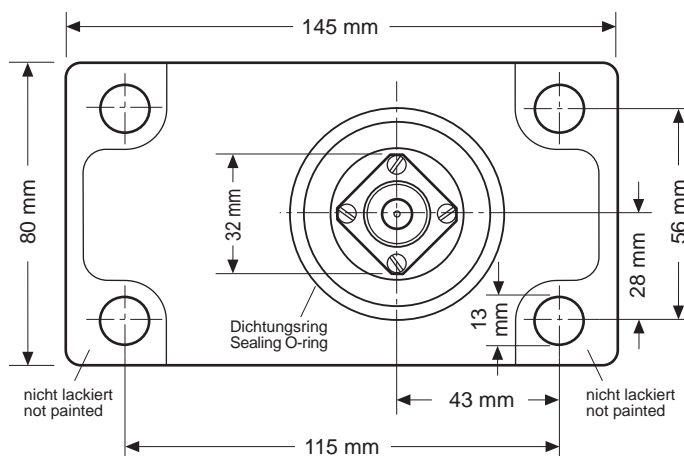

Mounting hole for the connector: 33 (max. 35) mm diameter.

Note: Keep mounting surface clear of paint for electrical contact.

Train Antenna

410 – 430 / 450 – 470 MHz

725892, K702121

KATHREIN

• 2 dB gain broadband antenna in fiberglass radome.

Type No.	725892	K702121
Input	N female	
Frequency range	410 – 430 MHz	450 – 470 MHz
VSWR	< 1.5	
Gain	2 dB (ref. to the quarter-wave antenna)	
Impedance	50 Ω	
Polarization	Vertical	
Max. power	640 W (at 50° C ambient temperature)	
Radome weight	365 g	
Weight	800 g	
Packing size (outside)	151 x 90 x 415 mm	

Material: Radiator and Flange: Aluminum.
Radome: Fiberglass, colour: Light grey.
All screws and nuts: Stainless steel.
Sealing: Neoprene and EPDM. **Note:** Don't use detergents that might harm the sealing.

Mounting: On a conductive surface with a minimum size of 50 x 50 cm by means of existing M10 studs.

Grounding and high voltage protection: This antenna approved by the "Deutsche Bahn AG" is DC grounded to protect against lightning and high-tension lines.

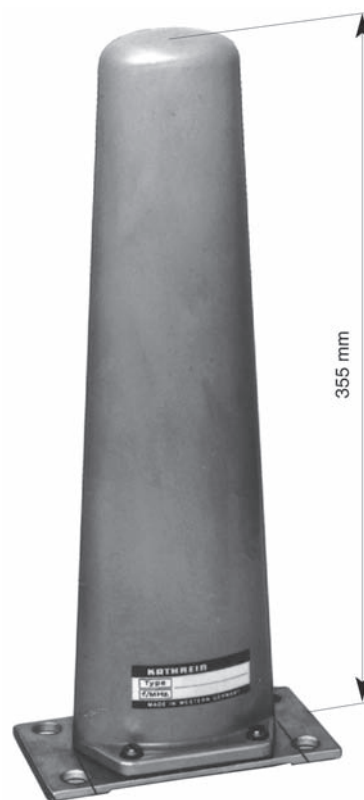

Mounting flange:

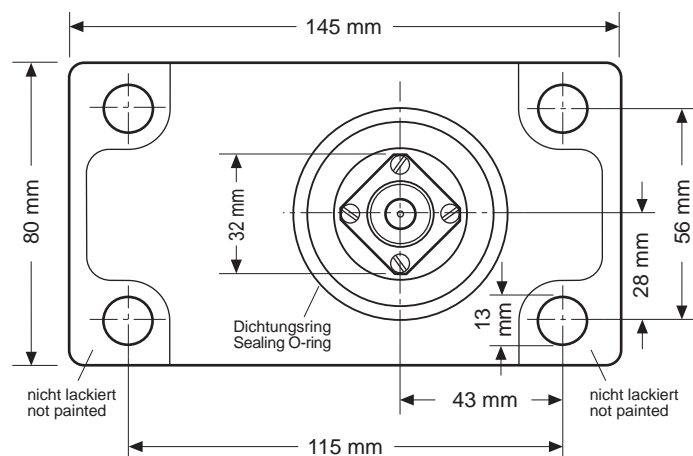

Mounting hole for the connector: 33 (max. 35) mm diameter.

Note: Keep mounting surface clear of paint for electrical contact.

Train Antenna

380 – 400 MHz and 870 – 960 MHz

741557

- Two-band antenna in fiberglass radome working in the 380 – 400 MHz and 870 – 960 MHz range.
- The antenna can be operated in both frequency ranges simultaneously by using the combiner 728954.

Type No.	741557
Input	N female
Frequency range	380 – 400 MHz and 870 – 960 MHz
VSWR	< 1.5
Gain	0 dB (ref. to the quarter-wave antenna)
Impedance	50 Ω
Polarization	Vertical
Max. power	500 W (at 50° C ambient temperature)
Radome weight	159 g
Total weight	500 g
Packing size (outside)	151 x 87 x 210 mm

Material: Radiator: Brass.
Flange: Aluminum.
Radome: Fiberglass; Colour: Light grey.
All screws and nuts: Stainless steel.
Sealing: Neoprene and rubber. **Note:** Don't use detergents that might harm the sealing.

Mounting: On a conductive surface with a minimum size of 50 x 50 cm by means of existing M10 studs.

Grounding and high voltage protection: This antenna approved by the "Deutsche Bahn AG" is DC grounded to protect against lightning and high-tension lines.

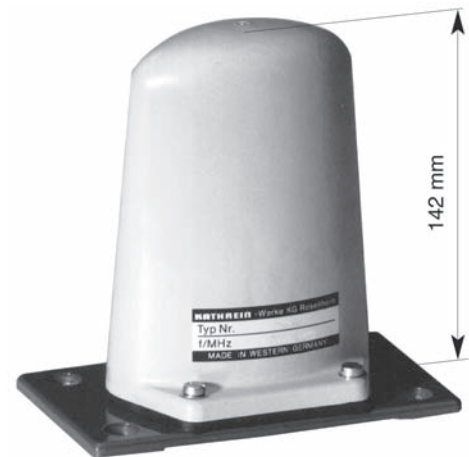

Mounting flange:

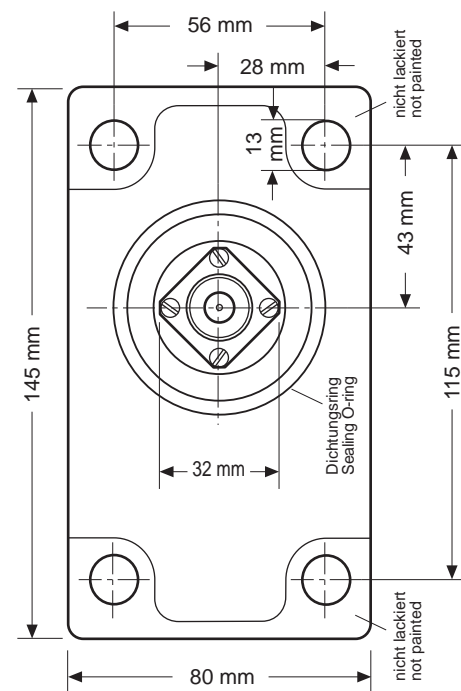

Mounting hole for the connector:

33 (max. 35) mm diameter.

Note: Keep mounting surface clear of paint for electrical contact.

Accessories: Combiner (order separately)

Type No.	728954
Pass band	
Band 1	68 – 470 MHz
Band 2	870 – 970 MHz
Insertion loss	
Port 1 ↔ Port 3	< 0.5 dB (68 – 470 MHz)
Port 2 ↔ Port 3	< 0.5 dB (870 – 970 MHz)
Isolation	> 45 dB
Port 1 ↔ Port 2	
VSWR	< 1.2
Impedance	50 Ω
Input power	
Band 1	< 50 W
Band 2	< 50 W
Intermodulation products	< -160 dBc (2nd/3rd order; with 2 x 20 W)
Temperature range	-20 ... +70 °C
Connectors	N female
Application	Indoor
DC transparency	
Port 1 ↔ Port 3	By-pass (max. 2500mA)
Port 2 ↔ Port 3	short circuited
Port 3 ↔ Port 2	stop
Weight	0.8 kg
Packing size	285 x 55 x 125 mm
Dimensions (w x h x d)	229.4 x 32 x 111.6 mm (without connectors)



Train Antenna

430 – 470 MHz and 870 – 960 MHz

87010009

KATHREIN

- Two-band Antenna: 430 – 470 MHz / 870 – 960 MHz
- Low profile antenna in fiberglass radome.
- The antenna fulfils the requirements according to EN 50155.

Type No.	87010009
Antenna two-band	
Input	N female
Frequency range	430 – 470 MHz 870 – 960 MHz
VSWR	< 1.5
Gain	0 dB (ref. to the quarter-wave antenna)
Impedance	50 Ω
Polarization	Vertical
Max. power	100 W (at 50° C ambient temperature)
Inner conductor	DC grounded
Radome weight	186 g
Total weight	Approx. 500 g
Packing size, L x W x H	150 x 90 x 190 mm
Height	150 mm

Material: Radiator: Copper and brass.
Flange: Aluminum. Radome: Fiberglass.
All screws and nuts: Stainless steel.
Colour: Grey.
Sealing: Neoprene and silicon. **Note:** Don't use detergents that might harm the sealing.

Mounting: On a conductive surface with a minimum size of 1000 x 1000 mm using 4 M10 bolts.

Grounding and high voltage protection: This antenna, tested by an independent institute and approved by the "Deutsche Bahn AG", is DC grounded to protect against lightning and high-tension lines.

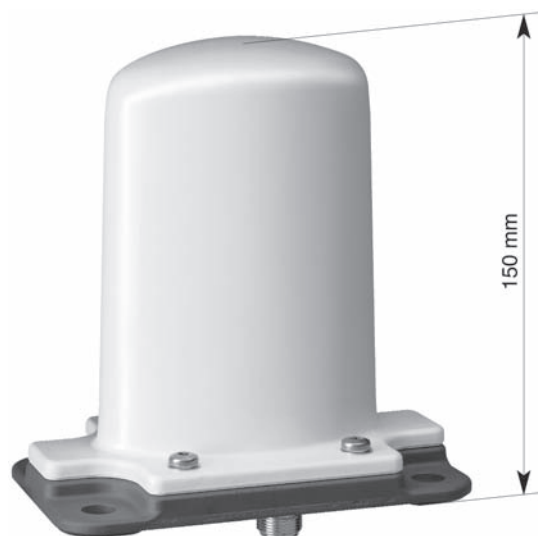

Mounting flange:

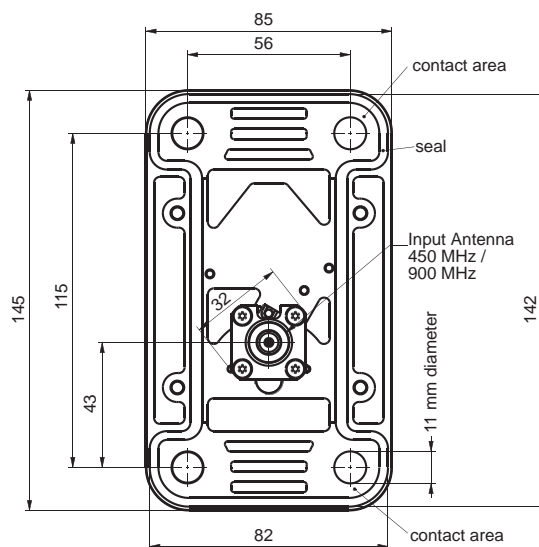

Mounting hole for the connector: 33 (max. 35) mm diameter.

Note: Keep mounting surface clear of paint for electrical contact.

Evenness of opposite surface 0.2 mm.

Use a cap nut or hex-head screw plus the enclosed sealing washer.

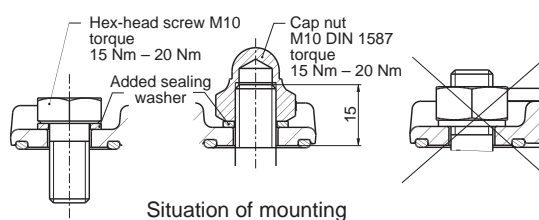

Train Antenna

KATHREIN

430 – 470 MHz / 870 – 960 MHz and GPS 1575 MHz 87010006

- Multi-band antenna: 430 – 470 MHz / 870 – 960 MHz and GPS.
- The antenna can be operated in all frequency ranges simultaneously.
- Low profile antenna in fiberglass radome.
- The antenna fulfils the requirements according to EN 50155.

Type No.	87010006
Antenna multi-band	
Input	N female
Frequency range	430 – 470 MHz 870 – 960 MHz
VSWR	< 1.5
Gain	0 dB (ref. to the quarter-wave antenna)
Impedance	50 Ω
Polarization	Vertical
Max. power	100 W (at 50° C ambient temperature)
Inner conductor	DC grounded
Antenna GPS	
Input	Cable RG 316/U of 225 mm length with TNC male connector
Frequency range	1575.42 ±1 MHz
VSWR	< 1.5
Polarization	Right hand circular
Gain (90° elevation)	2 dB (ref. to the circularly polarized isotropic antenna)
Impedance	50 Ω
Inner conductor	DC grounded
Radome weight	186 g
Weight	Approx. 500 g
Packing size	150 x 90 x 190 mm
Height	150 mm

- Material:** Radiator: Copper and brass.
Flange: Aluminum. Radome: Fiberglass.
All screws and nuts: Stainless steel.
Colour: Grey.
Sealing: Neoprene and silicon. **Note:** Don't use detergents that might harm the sealing.
- Mounting:** On a conductive surface with a minimum size of 1000 x 1000 mm using 4 M10 bolts.
- Grounding and high voltage protection:** This antenna, tested by an independent institute and approved by the "Deutsche Bahn AG", is DC grounded to protect against lightning and high-tension lines.
- Accessories:** Low noise amplifier GPS 86010142 (please order separately).
- Warning:** If the antenna is operated without the pre-amplifier type no. 86010142, please note the following points.
– Due to the fact that the inner conductor of the antenna GPS is DC grounded, the input of the GPS receiver is loaded with a DC short circuit. If the GPS receiver provides a remote DC power supply, this could damage the GPS receiver.
– At the input of the antenna GPS a level of –25 dB below the signal applied at the input of the antenna two-band appears. Depending on the level of the signal applied at the input of the antenna two-band, the GPS receiver may be overloaded or damaged.



Mounting flange:

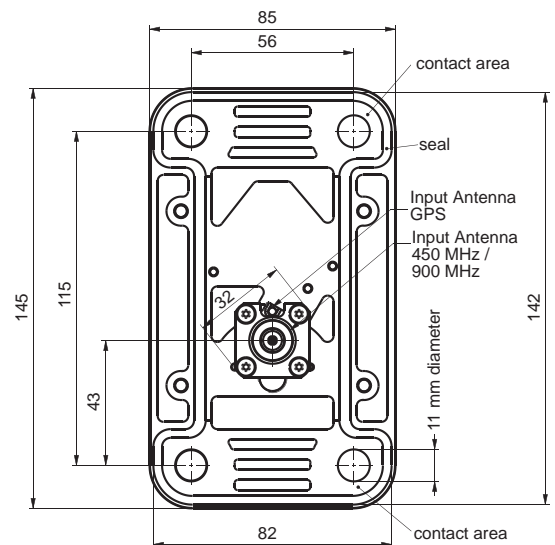

Mounting hole for the connector: 33 (max. 35) mm diameter.

Note: Keep mounting surface clear of paint for electrical contact.

Evenness of opposite surface 0.2 mm.

Use a cap nut or hex-head screw plus the enclosed sealing washer.

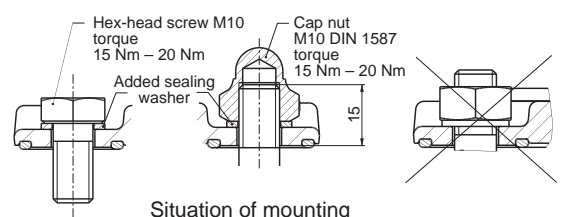

Train Antenna

450 – 470 MHz and 790 – 960 MHz

K702061

KATHREIN

- Two-band antenna in fiberglass radome working in the 450 – 470 MHz and 790 – 960 MHz range.
- The antenna can be operated in both frequency ranges simultaneously by using the combiner 728954.

Type No.	K702061
Input	N female
Frequency range	450 – 470 MHz and 790 – 960 MHz
VSWR	< 1.5
Gain	0 dB (ref. to the quarter-wave antenna)
Impedance	50 Ω
Polarization	Vertical
Max. power	500 W (at 50° C ambient temperature)
Radome weight	97 g
Total weight	500 g
Packing size (outside)	151 x 87 x 210 mm

Material: Radiator: Brass.
Flange: Aluminum.
Radome: Fiberglass; Colour: Light grey.
All screws and nuts: Stainless steel.
Sealing: Neoprene. **Note:** Don't use detergents that might harm the sealing.

Mounting: On a conductive surface with a minimum size of 50 x 50 cm by means of 4 existing M10 studs.

Grounding and high voltage protection: This antenna approved by the "Deutsche Bahn AG" is DC grounded to protect against lightning and high-tension lines.

Accessories: Combiner (order separately)

Type No.	728954
Pass band	
Band 1	68 – 470 MHz
Band 2	870 – 970 MHz
Insertion loss	
Port 1 ↔ Port 3	< 0.5 dB (68 – 470 MHz)
Port 2 ↔ Port 3	< 0.5 dB (870 – 970 MHz)
Isolation	
Port 1 ↔ Port 2	> 45 dB
VSWR	< 1.2
Impedance	50 Ω
Input power	
Band 1	< 50 W
Band 2	< 50 W
Intermodulation products	< -160 dBc (2nd/3rd order; with 2 x 20 W)
Temperature range	-20 ... +70 °C
Connectors	N female
Application	Indoor
DC transparency	
Port 1 ↔ Port 3	By-pass (max. 2500mA)
Port 2 ↔ Port 3	short circuited
Port 3 ↔ Port 2	stop
Weight	0.8 kg
Packing size	285 x 55 x 125 mm
Dimensions (w x h x d)	229.4 x 32 x 111.6 mm (without connectors)

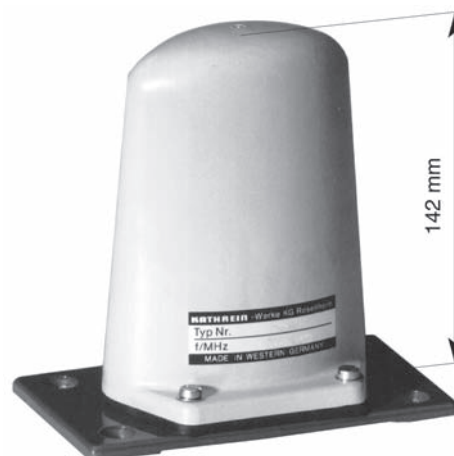

Mounting flange:

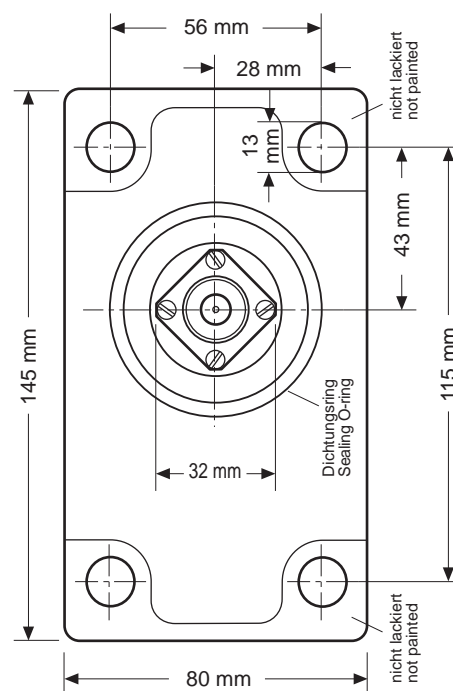

Mounting hole for the connector:

33 (max. 35) mm diameter.

Note: Keep mounting surface clear of paint for electrical contact.



Train Antenna 870 – 960 MHz 741009

- Broadband antenna of very low profile in fiberglass radome.
- Special radome suitable for high-speed trains.
- The antenna fulfils the requirements according to EN 50155.

Type No.	741009
Input	N female
Frequency range	870 – 960 MHz
VSWR	< 1.5
Gain	0 dB (ref. to quarter-wave antenna)
Impedance	50 Ω
Polarization	Vertical
Max. power	100 W (at 50 °C ambient temperature)
Radome weight	166 g
Total weight	500 g
Packing size (outside)	137 x 92 x 174 mm

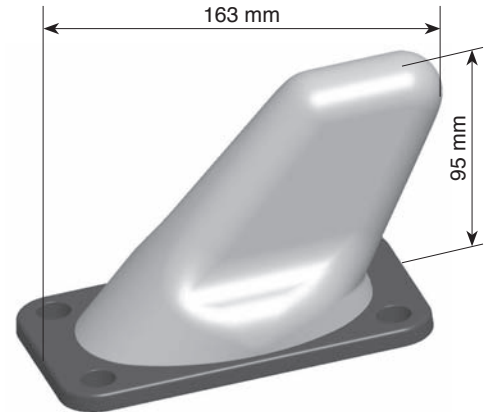

Material: Radiator: Brass.
Flange: Aluminum.
Radome: Fiberglass; Colour: Light grey.
All screws and nuts: Stainless steel.
Sealing: Neoprene and nitrile rubber. **Note:** Don't use detergents that might harm the sealing

Mounting: On a conductive surface of a minimum size of 50 x 50 cm by means of 4 existing M10 studs.

Grounding and high voltage protection: This antenna, which is approved by the "Deutsche Bahn AG", is DC grounded to protect against lightning and high-tension lines.

Mounting flange:

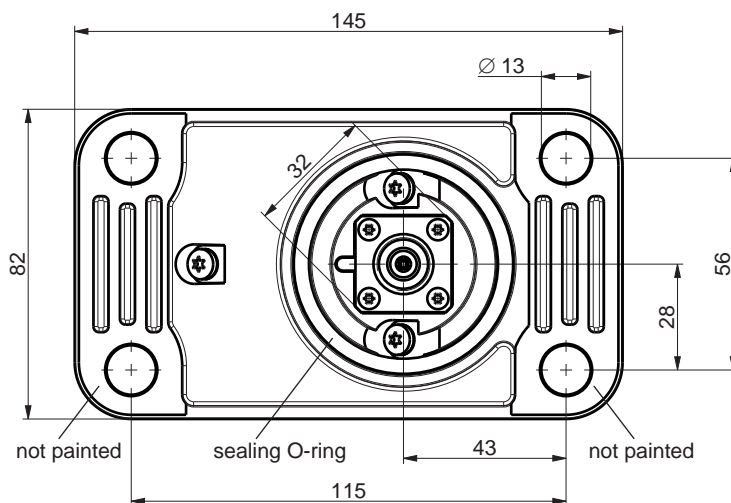

Mounting hole for the connector: 33 (max. 35) mm diameter.

Note: Keep mounting surface clear of paint for electrical contact.

All dimensions in mm.

Train Antenna

876 – 960 MHz

K7021631

KATHREIN

- Broadband gain antenna in fiberglass radome.

Type No.	K7021631
Input	N female
Frequency range	876 – 960 MHz
VSWR	< 1.5
Gain	3.5 dB (ref. to the quarter-wave antenna)
Impedance	50 Ω
Polarization	Vertical
Max. power	500 W (at 50 °C ambient temperature)
Radome weight	365 g
Total weight	1000 g
Packing size (outside)	151 x 90 x 415 mm

Material: Radiator: Brass.
Flange: Aluminum.
Radome: Fiberglass, colour: Light grey.
All screws and nuts: Stainless steel.
Sealing: Neoprene and EPDM. **Note:** Don't use detergents that might harm the sealing.

Mounting: On a conductive surface with a minimum size of 50 x 50 cm by means of 4 existing M10 studs.

Grounding and high voltage protection: This antenna approved by the "Deutsche Bahn AG" is DC grounded to protect against lightning and high-tension lines.

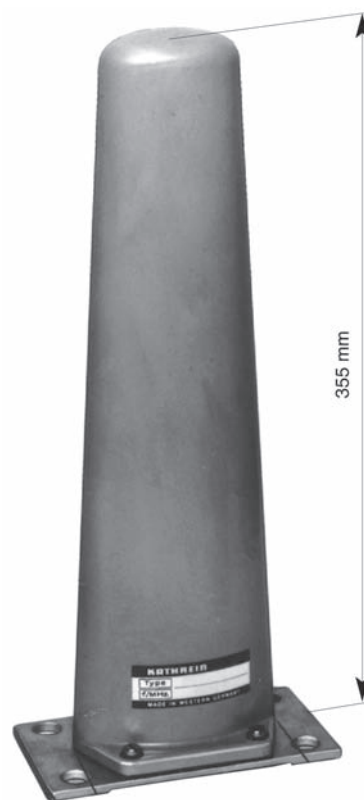

Mounting flange:

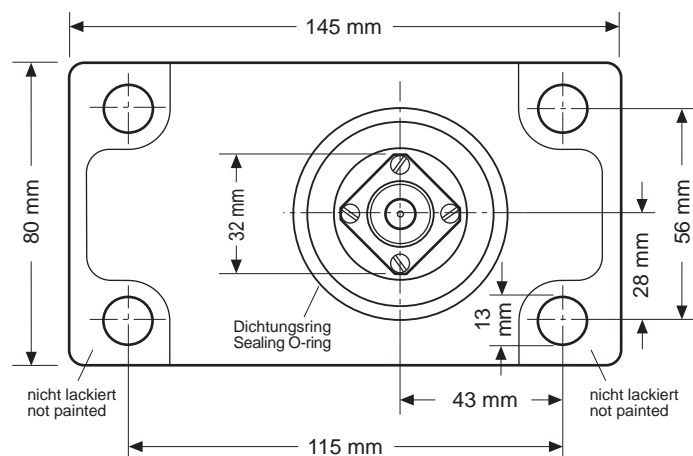

Mounting hole for the connector: 33 (max. 35) mm diameter.
Note: Keep mounting surface clear of paint for electrical contact.

Train Antenna

790 – 2700 MHz

87010007

- Multi-band antenna: 800/900/1800/1900/UMTS/LTE/W-LAN.
- The antenna can be operated in all frequency ranges simultaneously.
- Low profile antenna in fiberglass radome.
- The antenna fulfils the requirements according to EN 50155.

Type No.	87010007
Antenna multi-band	
Input	N female
Frequency range	790 – 2700 MHz
VSWR	790 – 806 MHz: < 2.2 806 – 870 MHz: < 2.0 870 – 2550 MHz: < 1.5 2550 – 2700 MHz: < 2.0
Gain	0 dB (ref. to the quarter-wave antenna)
Impedance	50 Ω
Polarization	Vertical
Max. power	100 W (at 50° C ambient temperature)
Inner conductor	DC grounded
Radome weight	115 g
Total weight	Approx. 500 g
Packing size, L x W x H	152 x 91 x 125 mm
Height	81 mm

Material: Radiator: Copper and brass.
Flange: Aluminum. Radome: Fiberglass.
All screws and nuts: Stainless steel.
Colour: Grey.
Sealing: Neoprene and silicon. **Note:** Don't use detergents that might harm the sealing.

Mounting: On a conductive surface with a minimum size of 50 x 50 cm using 4 M10 bolts.

Grounding and high voltage protection: This antenna, tested by an independent institute and approved by the "Deutsche Bahn AG", is DC grounded to protect against lightning and high-tension lines.

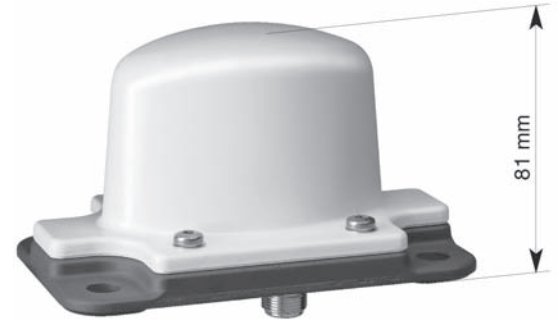

Mounting flange:

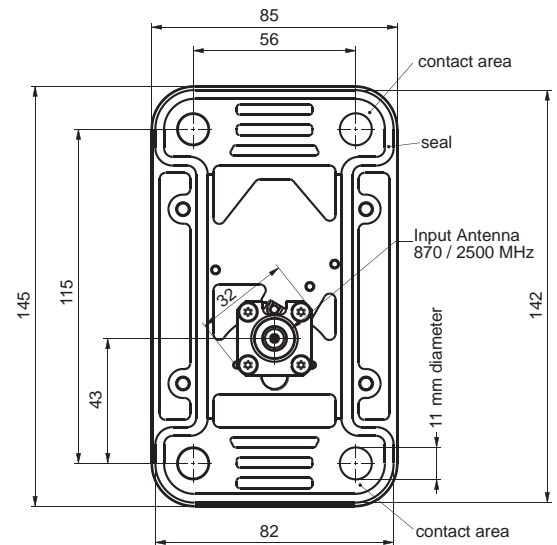

Mounting hole for the connector: 33 (max. 35) mm diameter.

Note: Keep mounting surface clear of paint for electrical contact.

Evenness of opposite surface 0.2 mm.

Use a cap nut or hex-head screw plus the enclosed sealing washer.

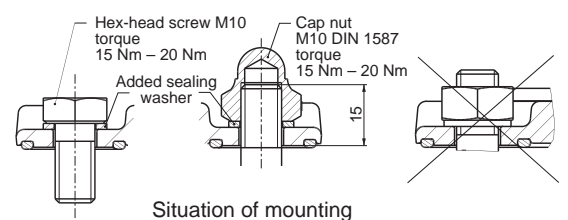

Situation of mounting

Train Antenna

790 – 2700 MHz and GPS 1575 MHz

87010003

KATHREIN

- Multi-band antenna: 800/900/1800/1900/UMTS/LTE/W-LAN and GPS.
- The antenna can be operated in all frequency ranges simultaneously.
- Low profile antenna in fiberglass radome.
- The antenna fulfils the requirements according to EN 50155.

Type No.	87010003
Antenna multi-band	
Input	N female
Frequency range	790 – 2700 MHz
VSWR	790 – 806 MHz: < 2.2 806 – 870 MHz: < 2.0 870 – 2550 MHz: < 1.5 2550 – 2700 MHz: < 2.0
Gain	0 dB (ref. to the quarter-wave antenna)
Impedance	50 Ω
Polarization	Vertical
Max. power	100 W (at 50° C ambient temperature)
Inner conductor	DC grounded
Antenna GPS	
Input	Cable RG 316/U of 225 mm length with TNC male connector
Frequency range	1575.42 ±1 MHz
VSWR	< 1.5
Polarization	Right hand circular
Gain (90° elevation)	2 dB (ref. to the circularly polarized isotropic antenna)
Impedance	50 Ω
Inner conductor	DC grounded
Radome weight	115 g
Total weight	Approx. 500 g
Packing size	152 x 91 x 125 mm
Height	81 mm

- Material:** Radiator: Copper and brass.
Flange: Aluminum. Radome: Fiberglass.
All screws and nuts: Stainless steel.
Colour: Grey.
Sealing: Neoprene and silicon. **Note:** Don't use detergents that might harm the sealing.
- Mounting:** On a conductive surface with a minimum size of 50 x 50 cm using 4 M10 bolts.
- Grounding and high voltage protection:** This antenna, tested by an independent institute and approved by the "Deutsche Bahn AG", is DC grounded to protect against lightning and high-tension lines.
- Accessories:** Low noise amplifier GPS 86010142 (please order separately).
- Warning:** If the antenna is operated without the pre-amplifier type no. 86010142, please note the following points.
– Due to the fact that the inner conductor of the antenna GPS is DC grounded, the input of the GPS receiver is loaded with a DC short circuit. If the GPS receiver provides a remote DC power supply, this could damage the GPS receiver.
– At the input of the antenna GPS a level of –25 dB below the signal applied at the input of the antenna multi-band appears. Depending on the level of the signal applied at the input of the antenna multi-band, the GPS receiver may be overloaded or damaged.



Mounting flange:

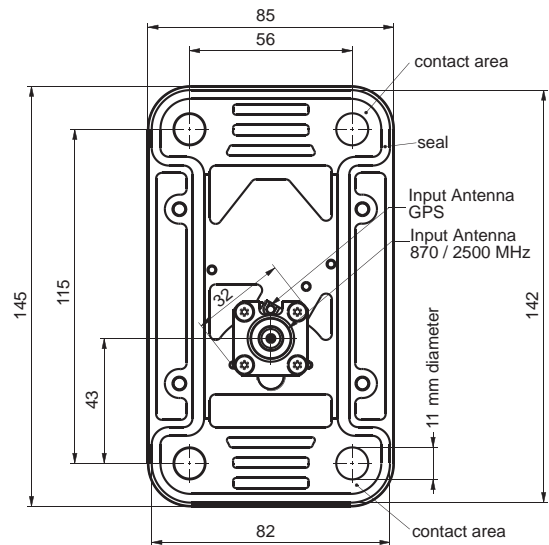

Mounting hole for the connector: 33 (max. 35) mm diameter.

Note: Keep mounting surface clear of paint for electrical contact.

Evenness of opposite surface 0.2 mm.

Use a cap nut or hex-head screw plus the enclosed sealing washer.

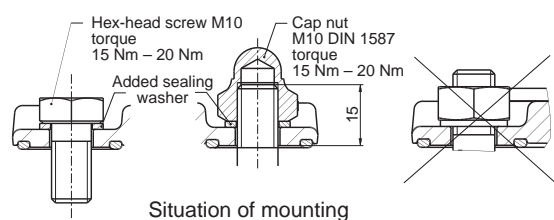

Train Antenna

1710 – 3800 MHz

87010010

- Multi-band antenna: 1800/1900/UMTS/LTE/W-LAN/WiMAX.
- The antenna can be operated in all frequency ranges simultaneously.
- Low profile antenna in fiberglass radome.
- The antenna fulfils the requirements according to EN 50155.

Type No.	87010010
Antenna multi-band	
Input	N female
Frequency range	1710 – 3800 MHz
VSWR	1710 – 1920 MHz: < 1.6 1920 – 3800 MHz: < 1.5
Gain	0 dB (ref. to the quarter-wave antenna)
Impedance	50 Ω
Polarization	Vertical
Max. power	100 W (at 50° C ambient temperature)
Inner conductor	DC grounded
Radome weight	115 g
Total weight	450 g
Packing size, L x W x H	152 x 91 x 125 mm
Height	81 mm

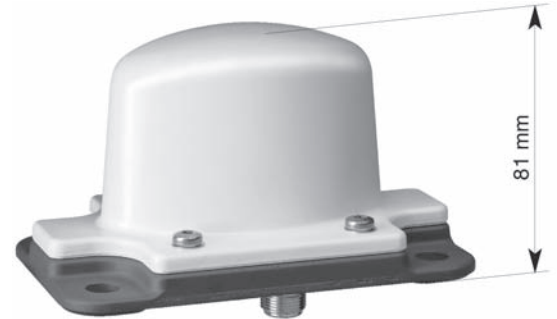

Material: Radiator: Copper and brass.
Flange: Aluminum. Radome: Fiberglass.
All screws and nuts: Stainless steel.
Colour: Grey.
Sealing: Neoprene and silicon. **Note:** Don't use detergents that might harm the sealing.

Mounting: On a conductive surface with a minimum size of 50 x 50 cm.

Grounding and high voltage protection: This antenna, tested by an independent institute and approved by the "Deutsche Bahn AG", is DC grounded to protect against lightning and high-tension lines.

Mounting flange:

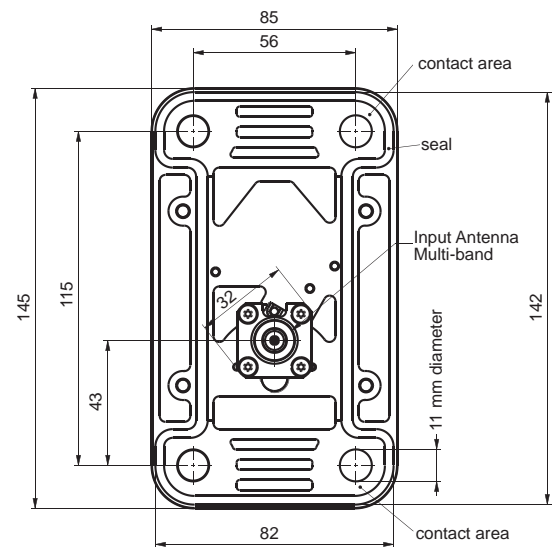

Mounting hole for the connector: 33 (max. 35) mm diameter.

Note: Keep mounting surface clear of paint for electrical contact.

Evenness of opposite surface 0.2 mm.

Use a cap nut or hex-head screw plus the enclosed sealing washer.

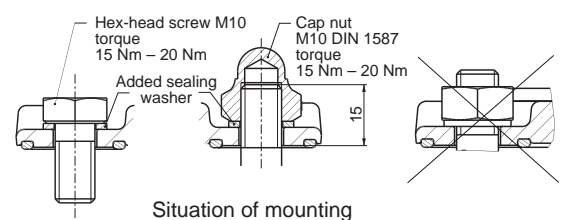

Train Antenna

1710 – 3800 MHz and GPS 1575 MHz

87010011

KATHREIN

- Multi-band antenna: 1800/1900/UMTS/LTE/W-LAN/WiMAX and GPS.
- The antenna can be operated in all frequency ranges simultaneously.
- Low profile antenna in fiberglass radome.
- The antenna fulfils the requirements according to EN 50155.

Type No.	87010011
Antenna multi-band	
Input	N female
Frequency range	1710 – 3800 MHz
VSWR	1710 – 1920 MHz: < 1.6 1920 – 3800 MHz: < 1.5
Gain	0 dB (ref. to the quarter-wave antenna)
Impedance	50 Ω
Polarization	Vertical
Max. power	100 W (at 50° C ambient temperature)
Inner conductor	DC grounded
Antenna GPS	
Input	Cable RG 316/U of 225 mm length with TNC male connector
Frequency range	1575.42 ±1 MHz
VSWR	< 1.5
Polarization	Right hand circular
Gain (90° elevation)	2 dB (ref. to the circularly polarized isotropic antenna)
Impedance	50 Ω
Inner conductor	DC grounded
Radome weight	115 g
Total weight	Approx. 500 g
Packing size	152 x 91 x 125 mm
Height	81 mm

Material: Radiator: Copper and brass.
Flange: Aluminum. Radome: Fiberglass.
All screws and nuts: Stainless steel.
Colour: Grey.
Sealing: Neoprene and silicon. **Note:** Don't use detergents that might harm the sealing.

Mounting: On a conductive surface with a minimum size of 50 x 50 cm.

Grounding and high voltage protection: This antenna, tested by an independent institute and approved by the "Deutsche Bahn AG", is DC grounded to protect against lightning and high-tension lines.

Accessories: Low noise amplifier GPS 86010142 (please order separately).

Warning: If the antenna is operated without the pre-amplifier type no. 86010142, please note the following points.

- Due to the fact that the inner conductor of the antenna GPS is DC grounded, the input of the GPS receiver is loaded with a DC short circuit. If the GPS receiver provides a remote DC power supply, this could damage the GPS receiver.
- At the input of the antenna GPS a level of –25 dB below the signal applied at the input of the antenna multi-band appears. Depending on the level of the signal applied at the input of the antenna multi-band, the GPS receiver may be overloaded or damaged.



Mounting flange:

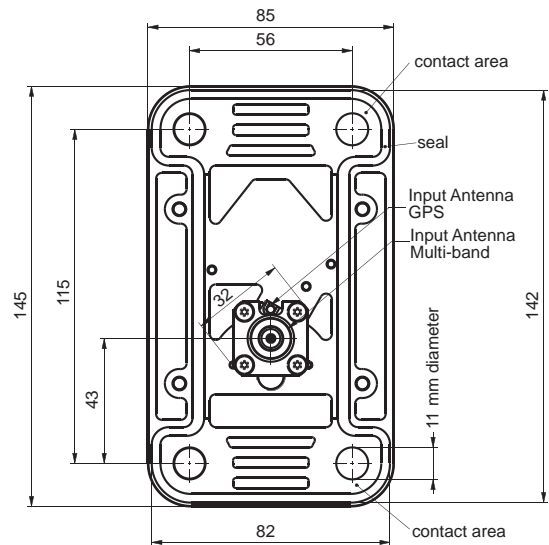

Mounting hole for the connector: 33 (max. 35) mm diameter.

Note: Keep mounting surface clear of paint for electrical contact.

Evenness of opposite surface 0.2 mm.

Use a cap nut or hex-head screw plus the enclosed sealing washer.

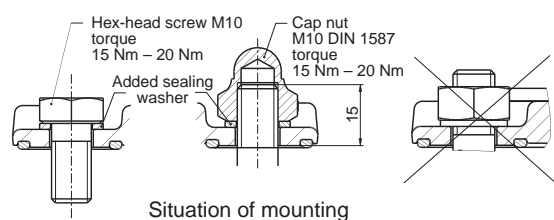

Situation of mounting

Low Noise Amplifier GPS 86010142

- The low noise amplifier 86010142 is designed for the use inside vehicles with train antennas with GPS.
- It includes a preselection filter to prevent the interference in case of simultaneous operation at the frequency range 380 – 960 / 1710 – 3800 MHz and GPS.
- The product fulfils the requirements according to EN 50155.

Block Diagram

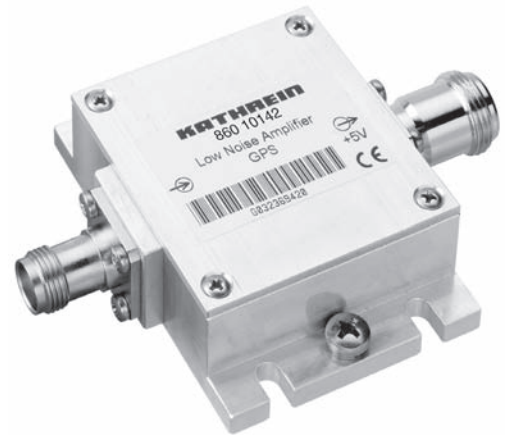
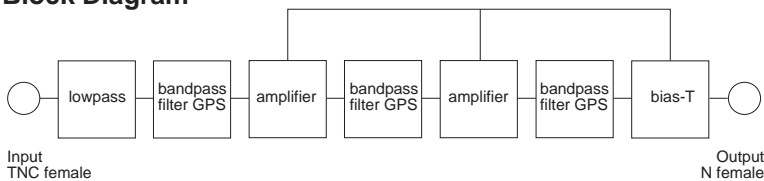

Type No.	86010142
Frequency	1575.42 MHz, L1-signal
Gain	25 ±2 dB
Noise figure	< 2.0 dB
VSWR (input, output)	< 1.8
Operation voltage	3.3 ... 5.5 V, ripple < 50 mV, supplied at inner conductor RF-output
Operation current	≤ 25 mA
Connector input	TNC female
Connector output	N female
Dimensions (w x h x l)	70 x 22 x 50 mm
Mounting	4 holes, 4.5 mm diameter

Additional features:

- The maximum input power at the input of the amplifier at the frequency range 380 – 960 MHz and 1710 – 3800 MHz is limited to +25 dBm.
- The noise level at the GPS-frequency generated by the operation at the frequency range 380 – 960 MHz and 1710 – 3800 MHz should not exceed the thermal noise level at the input of the GPS-amplifier, otherwise the noise figure will be increased.

Environmental conditions:

- Temperature range: -25 °C ... +55 °C (data as specified)
-40 °C ... +85 °C (extended range) *)
- Protection class: IP 54 (DIN 40050 / IEC 144)
(hanging installation position)

*) Extended range of operation:

Within an extended temperature range of -40 °C ... +85 °C and an extended supplied voltage range of 3.0 V ... 6.0 V operation is possible with the following restrictions:

Noise figure: < 2.5 dB

Gain: > 20 dB

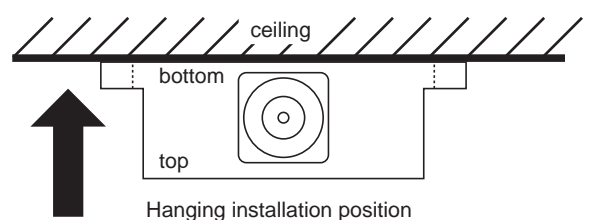
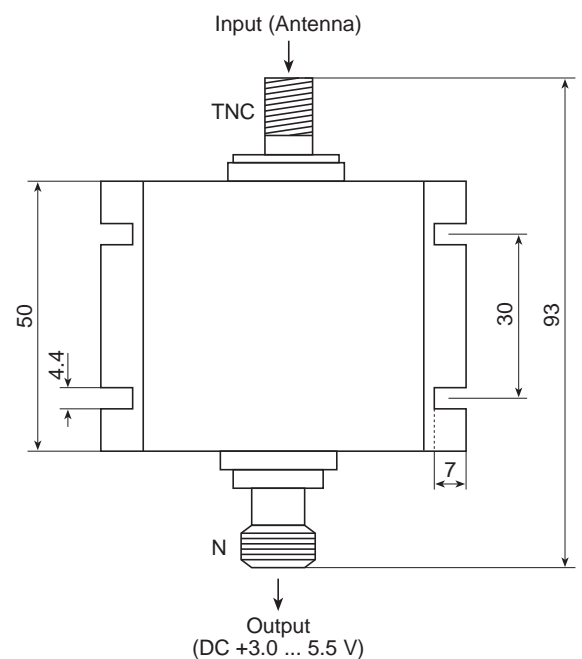
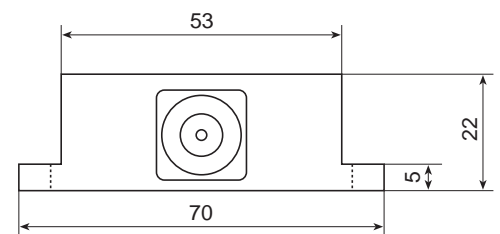

Abstract

Quality is the key

Train antennas made by Kathrein are well known as reliable and highly sophisticated products.

Our antennas are distinguished by excellent voltage protection against accidentally high voltage contacts due to well developed grounding elements implemented in the overall design.

Train antennas are faced to extreme environmental conditions and need to withstand tremendous operational conditions. The following documents should help to understand functionality and learn more about proper installation procedures.

Design

Depending on frequency and design constrains Kathrein antennas are designed as $\lambda/4$ radiators or as $\lambda/2$ radiators. For proper functionality $\lambda/4$ radiators have to be mounted on a conductive surface creating a ground plane. Train antennas are usually vertical polarized. Impedance is 50 Ohm.

Kathrein antennas are tested from an independent institute and type approved by the "Deutsche Bahn AG" (German Railway).

Key features of Kathrein antennas to pass the "Deutsche Bahn AG" requirements is the ability to limit connector voltage to 60 V in case of contact with the high tension lines. Current flow of 40kA over a time frame of 100 ms and high voltages of up to 42kV could be applied under worst case conditions.



870 – 960 MHz



Broadband + GPS
(incl. amplifier)

Installation

Ground Plane

Fundamental RF basics require metallic surfaces for certain antenna designs. Utilizing $\lambda/4$ technologies depends on a sufficient ground plane surface to finally distribute RF wave into the surroundings. Thus those particular antennas need to be mounted against a conductive surface to create the required ground plane.

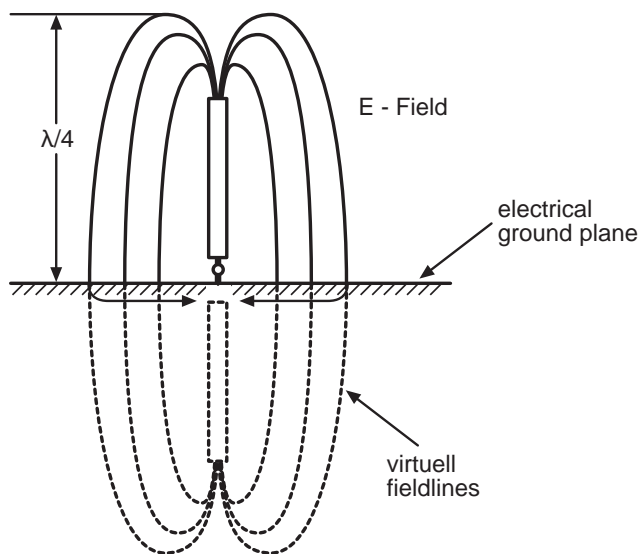
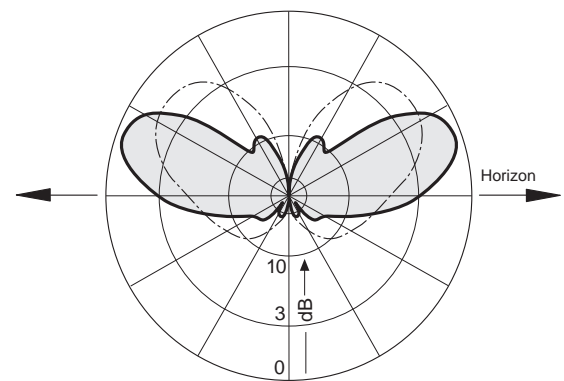

Figure 1: Electrical field and radiation pattern of a $\lambda/4$ antenna design

Each data sheet leaves detailed information about surface size. We strongly recommend not to stay under the minimum mounting requirements. Antennas easily will lose VSWR performance, and radiation pattern may change dramatically.



Metallic Surfaces

In most of the cases the roof of trains is made out of metallic materials. These materials have a reasonable conductivity to achieve best radiation results. For safety reasons these surfaces need to offer sufficient grounding to finally guide high voltages and currents to the ground.

Non-Metallic Surfaces

Trains designs appear more and more with non-metallic surfaces mostly present at the front or the end of a train. Apparently those areas are preferred installation areas for antennas.

As explained previously antennas require ground planes made out of conductive material. Several

designs may apply to create such a plane. Metallic foils might be placed underneath a non-metallic train body. Other metals might be laminated into Fiberglass constructions. The antenna flange needs to have good electrical contact to these additional ground planes

The same mandatory rule applies as with metallic surfaces: A sufficient grounding of the antenna needs to be considered in the design. Any kind of grounding needs to handle high currents and voltages, and finally lead it to the ground.

Grounding

In case of an accident or a failure of the high tension line (overhead contact line) high voltage and current might be applied to the antenna. To protect personal and equipment, connector voltage of the antenna is supposed not to exceed 60 V. To guarantee low connector voltages, antenna flanges need to be grounded thoroughly.

- Unpainted areas near the four mounting holes of the antenna flange.

To achieve best conductivity mounting surfaces at the antenna socket and the mating surface of the train should be clean. Any paint residues or other pollution needs to be removed prior to the mounting process.

- In case of non-metallic roof surfaces with an additional ground plane of e. g. thin material, a separate grounding of the antenna mounting flange is required.

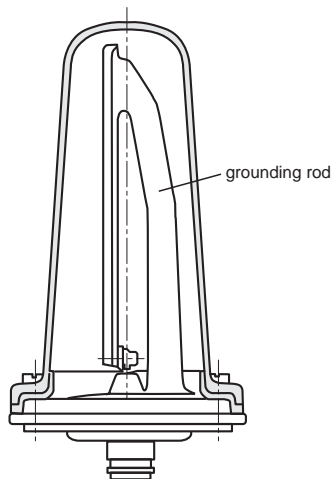

Figure 2: Inside grounding

Mounting

Most antennas are designed with a standardized foot print of the mounting socket. Dimensions are stated in the data sheets.

Mounting Sockets

Most antenna sockets offer four screw holes to tighten the flange against the mounting surface.

We recommend the following:

- Mounting against a separate flange with integrated mounting bolts. This flange is usually welded to the train.

In general, mounting screws or nuts should not add more than 15 mm to the mounting surface, especially if cap nuts are used.

In case of an antenna installation with screws through the antenna socket into the vehicle, particular attention should be paid to the sealing of the screws under consideration of the grounding instructions.

Mounting Position

The antennas have to be mounted directly to the ground plane.

Depending on the overall mounting situation (please refer to “Obstacles close to the antenna”) it’s tempted to elevate antennas against the trains roof with high flanges or other challenging constructions. To avoid mistuning and malfunctioning antennas it is mandatory not to follow these installation ideas. Resonance frequency, radiation pattern, and VSWR would change dramatically or could be lost completely.

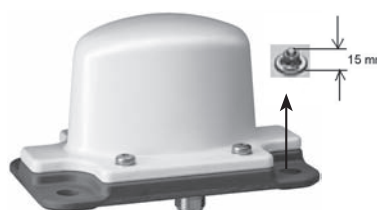

Figure 3: Low profile broad band antenna with mounting screws

Sealing

To avoid corrosion and leaky into the vehicle, antenna connectors need to be sealed against the mounting plate. Every Kathrein antenna is supplied with detailed mounting instructions. An O-ring is supplied with each antenna to seal the through hole into the vehicles body against the antennas connector. For certain types, this ring runs around the whole flange. To achieve advanced

sealing mating surfaces between the antenna socket and mounting flange/mounting surface are supposed of being flat.

Sealing also needs to be performed around mounting holes if no mounting flanges are used. Corrosion at mating surfaces between the antenna and the mounting plane is critical for proper function of the antenna.

Painting

For optical reasons the color of train antennas sometimes has to match certain colors. Kathrein antennas are particularly suitable for subsequent, long-lasting painting since the visible parts (radomes) are generally made of fiberglass (polyester), to which paint adheres very well. A thin layer of paint eventually has only a negligible influence on the electrical characteristics.

General remarks:

- We recommend that painting is only performed by qualified professional painting companies. If required painting on site may also be possible (and permissible).

- We recommend that painting should only be applied to visible surfaces: e.g.
 - Fiberglass radome
 - Antenna socket, upper surface – please refer to instructions stated in our data sheets

- The contact area on the lower part of the flange must be kept unpainted at all events.

- Suitable commercial paints consist of one or two components. The manufacturer's instruction for use and processing must be observed. Paints with metallic effects or metallic components are not permissible.

Obstacles close to the antenna

For proper wave propagation from the antenna into the surroundings a flat roof without any obstacles would be preferred.

Trains sometimes have a number of structures for multiple purposes on the trains top. Any obstacles close to the antenna may impact radiation pattern and

radiated waves. It is difficult to leave general guidelines about minimum distances. As a rule over the thumb antennas should face no obstacles within a radius of approximately 1 m or more.

Distances to other antennas

The distance to other antennas depends on the required antenna isolation. This value has to be clarified with the suppliers of the installed mobile communication system.

An isolation of 30 dB is a preferred value. As a rule over the thumb, a distance of approximately

5–7 Lambda is required for antennas operating the same frequency band.

Due to the selectivity of different systems, antennas operating in different frequency bands require distances that can be even smaller.

	733707	K702061	727313	K50222...	K702021	87010011	87010010	87010009
UL94 HB	•	•	•	•	•	•	•	•
DIN EN 45545-2: 2013	•	•	•	•	–	•	•	•
DIN 5510 T2	–	•	–	–	•	•	•	•
IP Class (when mounted properly)	IP 66	IP 66	IP 66	IP 66	IP 66	IP 66	IP 66	IP 66
EN 50122-1	•	•	•	•	•	•	•	•
EN 50125	•	•	•	•	•	•	•	•
EN 50155	•	•	•	•	•	•	•	•
EN 60068-2-1	•	•	•	•	•	•	•	•
EN 60068-2-2	•	•	•	•	•	•	•	•
EN 60068-2-6	•	•	•	•	•	•	•	•
EN 60068-2-27	•	•	•	•	•	•	•	•
EN 60068-2-30	•	•	•	•	•	•	•	•
EN 61373	•	•	•	•	•	•	•	•
ETS 300 019-1-2 class 2.2	•	•	•	•	•	•	•	•
ETS 300 019-1-1 T 1.2	•	•	•	•	•	•	•	•
ETS 300 019-1-5 T 5.2	•	•	•	•	•	•	•	•
ETS 300 019-2-2 T 2.2	•	•	•	•	•	•	•	•
ETS 300 019-1-2 T 1.2	•	•	•	•	•	•	•	•

- Product complies with the standard/guidelines
- Product does not meet the standard/guidelines

87010008	87010006	87010005	87010007	87010003	741557	K702121	725892	741009	K7021621	K7021631
•	•	•	•	•	•	•	•	•	•	•
•	•	•	•	•	•	•	•	•	•	•
•	•	•	•	•	•	–	–	•	–	–
IP 66	IP 66	IP 66	IP 66	IP 66	IP 66	IP 66	IP 66	IP 66	IP 66	IP 66
•	•	•	•	•	•	•	•	•	•	•
•	•	•	•	•	•	•	•	•	•	•
•	•	•	•	•	•	•	•	•	•	•
•	•	•	•	•	•	•	•	•	•	•
•	•	•	•	•	•	•	•	•	•	•
•	•	•	•	•	•	•	•	•	•	•
•	•	•	•	•	•	•	•	•	•	•
•	•	•	•	•	•	•	•	•	•	•
•	•	•	•	•	•	•	•	•	•	•
•	•	•	•	•	•	•	•	•	•	•
•	•	•	•	•	•	•	•	•	•	•
•	•	•	•	•	•	•	•	•	•	•
•	•	•	•	•	•	•	•	•	•	•
•	•	•	•	•	•	•	•	•	•	•
•	•	•	•	•	•	•	•	•	•	•

- Product complies with the standard/guidelines
- Product does not meet the standard/guidelines

KATHREIN-Werke KG
Anton-Kathrein-Straße 1-3
D-83022 Rosenheim, GERMANY
Phone +49 (0) 80 31 1 84-0
Fax +49 (0) 80 31 1 84-8 20
www.kathrein.com | mobilcom@kathrein.de

KATHREIN

Train Antenna

694 – 6000 MHz and GPS, GLONASS, BEIDOU

87010012

- Multi-band antenna: 700/800/900/1800/1900/UMTS/2600/3500/5000/ LTE/W-LAN and GPS, GLONASS, BEIDOU.
- The antenna can be operated in all frequency ranges simultaneously.
- Low profile antenna in fiberglass radome.
- The antenna fulfils the requirements according to EN 50155.

Type No.	87010012	
Antenna multi-band		
Input	N female	
Frequency range	MHz	694 – 6000
VSWR	694 – 960 MHz: < 1.5 1350 – 6000 MHz: < 1.8	
Gain	dB	0 (ref. to the quarter-wave antenna)
Impedance	Ω	50
Polarization	Vertical	
Max. power	W	40 (at 50° C ambient temperature)
Inner conductor	DC grounded	
Antenna GPS / Galileo / GLONASS / BEIDOU		
Center frequency	MHz	1581 ± 5
Bandwidth in 10 dB	MHz	49
Polarization	Right hand circular	
Peak gain at Fc	dBic	3
Integrated LNA		
Frequency range	MHz	1550 – 1610
VSWR	< 2.0	
Impedance	Ω	50
Gain	dB	23 ± 2
Noise figure	dB	typ. 1.0, max. 1.5
Operation voltage	V	2.5 ... 5.5
Operation current	mA	typ. 7, max. 10
Input	SMA female, 110 mm 4.3 inches cable length	
Radome weight	g lb	180 0,4
Total weight	g lb	630 1,4
Packing size	mm inches	170 x 120 x 100 6.7 x 4.7 x 3.9
Height	mm inches	93 3.7

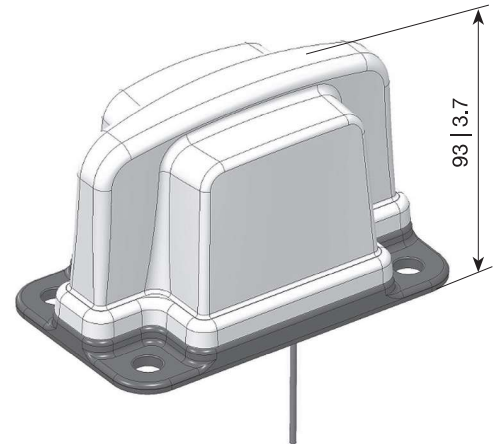

Mounting flange:

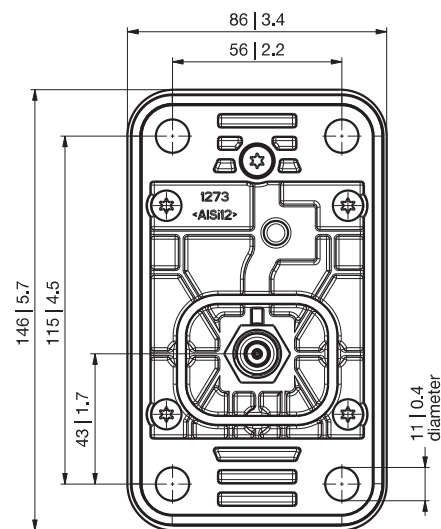

Mounting hole for the connector: 33 (max. 35) mm | 1.3 (max. 1.4) inches diameter.

Note: Keep mounting surface clear of paint for electrical contact.

Evenness of opposite surface 0.2 mm | 0.008 inches.

Use a cap nut or hex-head screw plus the enclosed sealing washer.

Material: Radiator: Aluminum
Flange: Aluminum. Radome: Fiberglass.
All screws and nuts: Stainless steel.
Colour: Grey.
Sealing: Polyurethan and silicone. **Note:** Don't use detergents that might harm the sealing.

Mounting: On a conductive surface with a minimum size of 50 x 50 cm | 19.7 x 19.7 inches using 4 M10 bolts.

Grounding and high voltage protection: This antenna, tested by an independent institute, is DC grounded to protect against lightning and high-tension lines.

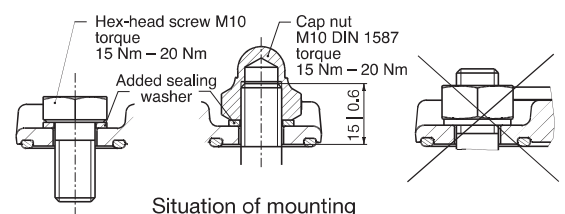

Situation of mounting

All dimensions in mm | inches

Train Antenna

694 – 6000 MHz and GPS, GLONASS, BEIDOU

87010012

KATHREIN

Fire prevention:	UL94 (HB) DIN 5510 T2 DIN EN 45545-2: 2013
IP class:	IP 66 (when product is mounted properly)
Standards:	EN 50122-1 EN 50125 EN 50155 EN 60068-2-1 EN 60068-2-2 EN 60068-2-6 EN 60068-2-27 EN 60068-2-30 EN 61373 ETS 300 019-1-2 class 2.2 ETS 300 019-1-1 T 1.2 ETS 300 019-1-5 T 5.2 ETS 300 019-2-2 T 2.2 ETS 300 019-1-2 T 1.2

936.5339/a Subject to alteration.

Train Antenna

694 – 6000 MHz and GPS, GLONASS, BEIDOU

87010022

KATHREIN

- Multi-band antenna: 700/800/900/1800/1900/UMTS/2600/3500/5000/ LTE/W-LAN and GPS, GLONASS, BEIDOU.
- The antenna can be operated in all frequency ranges simultaneously.
- Low profile antenna in fiberglass radome.
- The antenna fulfils the requirements according to EN 50155.

Type No.	87010022	
Antenna multi-band		
Input	N female	
Frequency range	MHz	694 – 6000
VSWR	694 – 960 MHz: < 1.5 1350 – 6000 MHz: < 1.8	
Gain	dB	0 (ref. to the quarter-wave antenna)
Impedance	Ω	50
Polarization	Vertical	
Max. power	W	40 (at 50° C ambient temperature)
Inner conductor	DC grounded	
Antenna GPS / Galileo / GLONASS / BEIDOU		
Center frequency	MHz	1581 ± 5
Bandwidth in 10 dB	MHz	49
Polarization	Right hand circular	
Peak gain at Fc	dBic	3
Integrated LNA		
Frequency range	MHz	1550 – 1610
VSWR	< 2.0	
Impedance	Ω	50
Gain	dB	23 ± 2
Noise figure	dB	typ. 1.0, max. 1.5
Operation voltage	V	2.5 ... 5.5
Operation current	mA	typ. 7, max. 10
Input	N female, 110 mm 4.3 inches cable length	
Radome weight	g lb	180 0,4
Total weight	g lb	630 1,4
Packing size	mm inches	170 x 120 x 100 6.7 x 4.7 x 3.9
Height	mm inches	93 3.7

Material: Radiator: Aluminum
Flange: Aluminum. Radome: Fiberglass.
All screws and nuts: Stainless steel.
Colour: Grey.
Sealing: Polyurethan and silicone. **Note:** Don't use detergents that might harm the sealing.

Mounting: On a conductive surface with a minimum size of 50 x 50 cm | 19.7 x 19.7 inches using 4 M10 bolts.

Grounding and high voltage protection: This antenna, tested by an independent institute, is DC grounded to protect against lightning and high-tension lines.

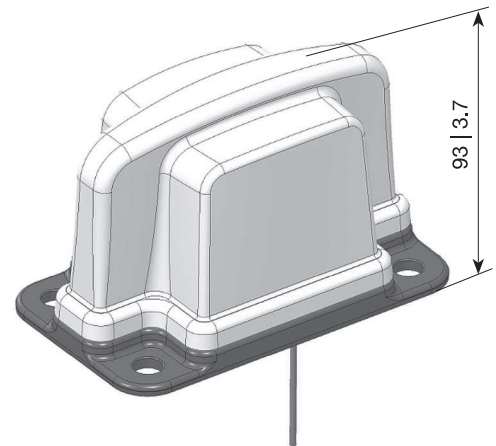

Mounting flange:

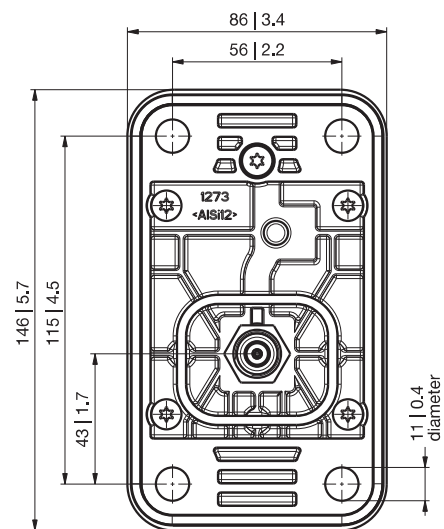

Mounting hole for the connector: 33 (max. 35) mm | 1.3 (max. 1.4) inches diameter.

Note: Keep mounting surface clear of paint for electrical contact.

Evenness of opposite surface 0.2 mm | 0.008 inches.

Use a cap nut or hex-head screw plus the enclosed sealing washer.

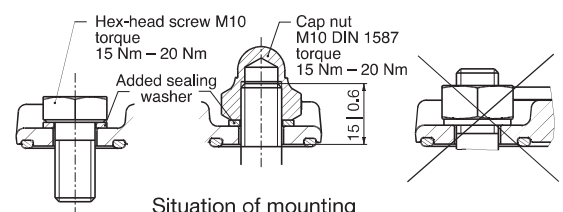

Situation of mounting

All dimensions in mm | inches

936.5626/a Subject to alteration.

Train Antenna

694 – 6000 MHz and GPS, GLONASS, BEIDOU

87010022

KATHREIN

Fire prevention:	UL94 (HB) DIN 5510 T2 DIN EN 45545-2: 2013
IP class:	IP 66 (when product is mounted properly)
Standards:	EN 50122-1 EN 50125 EN 50124-1 EN 50155 EN 60068-2-1 EN 60068-2-2 EN 60068-2-6 EN 60068-2-27 EN 60068-2-30 EN 61373 ETS 300 019-1-2 class 2.2 ETS 300 019-1-1 T 1.2 ETS 300 019-1-5 T 5.2 ETS 300 019-2-2 T 2.2 ETS 300 019-1-2 T 1.2

936.5626/a Subject to alteration.

Train Antenna

694 – 6000 MHz and GPS, GLONASS, BEIDOU

87010032

- Multi-band antenna: 700/800/900/1800/1900/UMTS/2600/3500/5000/ LTE/W-LAN and GPS, GLONASS, BEIDOU.
- The antenna can be operated in all frequency ranges simultaneously.
- Low profile antenna in fiberglass radome.
- The antenna fulfils the requirements according to EN 50155.

Type No.		87010032
Antenna multi-band		
Input		N female
Frequency range	MHz	694 – 6000
VSWR		694 – 960 MHz: < 1.5 1350 – 6000 MHz: < 1.8
Gain	dB	0 (ref. to the quarter-wave antenna)
Impedance	Ω	50
Polarization		Vertical
Max. power	W	40 (at 50° C ambient temperature)
Inner conductor		DC grounded
Antenna GPS / Galileo / GLONASS / BEIDOU		
Frequency range	MHz	F center 1581, Bandwidth in 10 dB > 49 MHz
Polarization		Right hand circular
Impedance	Ω	50
Input		TNC male with cable
Radome weight	g lb	180 0.4
Total weight	g lb	~ 610 ~ 1.34
Packing size	mm inches	170 x 120 x 100 6.7 x 4.7 x 3.9
Height	mm inches	93 3.7

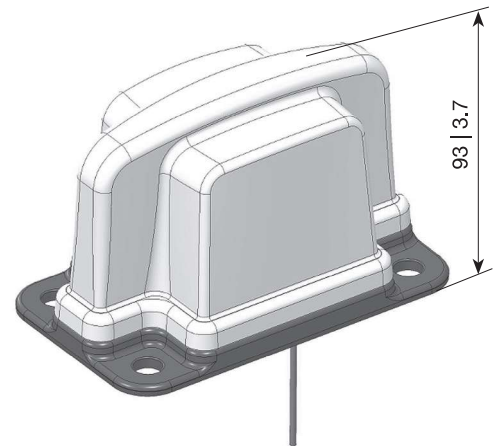

- Material:** Radiator: Aluminum
Flange: Aluminum, Radome: Fiberglass.
All screws and nuts: Stainless steel.
Colour: Grey.
Sealing: Polyurethan and silicon. **Note:** Don't use detergents that might harm the sealing.
- Mounting:** On a conductive surface with a minimum size of 50 x 50 cm | 19.7 x 19.7 inches using 4 M10 bolts.
- Grounding and high voltage protection:** This antenna, tested by an independent institute, is DC grounded to protect against lightning and high-tension lines.
- Accessories:** Low noise amplifier GPS 86010142 (please order separately).

Mounting flange:

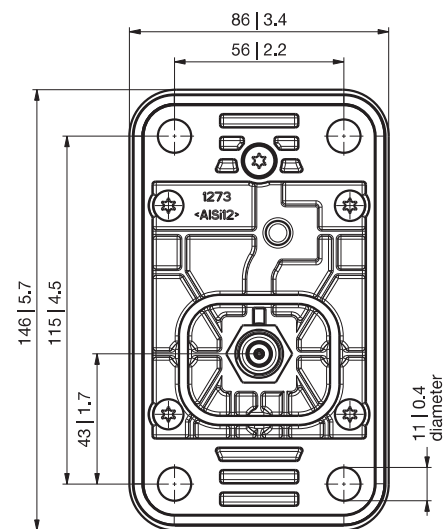

Mounting hole for the connector: 33 (max. 35) mm | 1.3 (max. 1.4) inches diameter.

Note: Keep mounting surface clear of paint for electrical contact.

Evenness of opposite surface 0.2 mm | 0.008 inches.

Use a cap nut or hex-head screw plus the enclosed sealing washer.

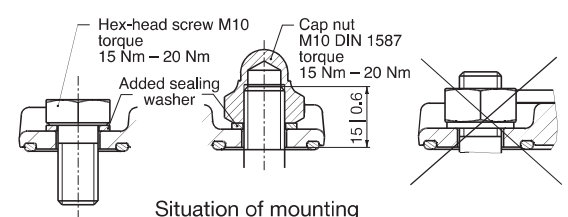

Situation of mounting

All dimensions in mm | inches

Train Antenna

694 – 6000 MHz and GPS, GLONASS, BEIDOU

87010012

KATHREIN

Fire prevention: UL94 (HB)
DIN 5510 T2
DIN EN 45545-2: 2013

IP class: IP 66 (when product is mounted properly)

Standards: EN 50122-1
EN 50125
EN 50155
EN 60068-2-1
EN 60068-2-2
EN 60068-2-6
EN 60068-2-27
EN 60068-2-30
EN 61373
ETS 300 019-1-2 class 2.2
ETS 300 019-1-1 T 1.2
ETS 300 019-1-5 T 5.2
ETS 300 019-2-2 T 2.2
ETS 300 019-1-2 T 1.2

936.A3588/a Subject to alteration.

Train Antenna

694 – 2700 MHz and GPS 1575 MHz

87010023

- Multi-band antenna: 700/800/900/1800/1900/UMTS/2600/LTE/W-LAN and GPS.
- The antenna can be operated in all frequency ranges simultaneously.
- Low profile antenna in fiberglass radome.
- The antenna fulfils the requirements according to EN 50155.

Type No.		87010023
Antenna multi-band		
Input		N female
Frequency range	MHz	694 – 2700
VSWR		694 – 720 MHz: < 2.2 720 – 870 MHz: < 2.0 870 – 925 MHz: < 1.8 925 – 2700 MHz: < 2.0
Gain	dB	0 (ref. to the quarter-wave antenna)
Impedance	Ω	50
Polarization		Vertical
Max. power	W	100 (at 50° C ambient temperature)
Inner conductor		DC grounded
Antenna GPS		
Input		Cable RG 316/U of 225 mm length with TNC male connector
Frequency range	MHz	1575,42 \pm 1
VSWR		< 1.5
Polarization		Right hand circular
Gain (90° elevation)	dB	2 (ref. to the circularly polarized isotropic antenna)
Impedance	Ω	50
Inner conductor		DC grounded
Radome weight	g lb	115 0,25
Total weight	g lb	540 1,1
Packing size	mm inches	152 x 91 x 125 6.0 x 3.6 x 4.9
Height	mm inches	81 3,2

Material: Radiator: Copper and brass.
Flange: Aluminum. Radome: Fiberglass.
All screws and nuts: Stainless steel.
Colour: Grey.
Sealing: Neoprene and silicon. **Note:** Don't use detergents that might harm the sealing.

Mounting: On a conductive surface with a minimum size of 50 x 50 cm | 19.7 x 19.7 inches using 4 M10 bolts.

Grounding and high voltage protection: This antenna, tested by an independent institute, is DC grounded to protect against lightning and high-tension lines.

Accessories: Low noise amplifier GPS 86010142 (please order separately).

Warning: If the antenna is operated without the pre-amplifier type no. 86010142, please note the following points.

- Due to the fact that the inner conductor of the antenna GPS is DC grounded, the input of the GPS receiver is loaded with a DC short circuit. If the GPS receiver provides a remote DC power supply, this could damage the GPS receiver.
- At the input of the antenna GPS a level of -25 dB below the signal applied at the input of the antenna multi-band appears. Depending on the level of the signal applied at the input of the antenna multi-band, the GPS receiver may be overloaded or damaged.



Mounting flange:

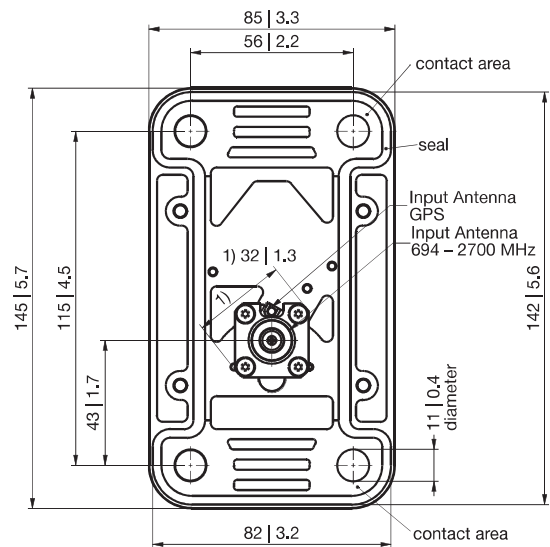

Mounting hole for the connector: 33 (max. 35) mm | 1,3 (max. 1,4) inches diameter.

Note: Keep mounting surface clear of paint for electrical contact.

Evenness of opposite surface 0,2 mm | 0,008 inches.

Use a cap nut or hex-head screw plus the enclosed sealing washer.

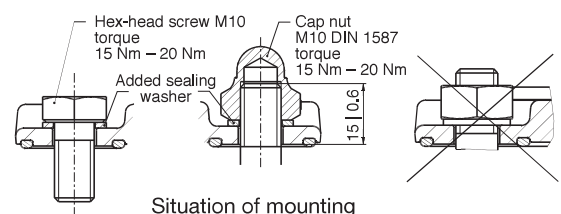

Situation of mounting

All dimensions in mm | inches